

A wide-angle, high-altitude photograph of the Grand Canyon. The canyon's layered rock formations are visible in shades of red, orange, and tan, with deep shadows and bright highlights. The sky is filled with white and grey clouds. The text is centered in the upper half of the image.

**National Environmental Health Association
Hilton El Conquistador
Tucson, AZ
June 22-23, 2008**

AEX
CONVENTION SERVICES

Show Name: National Environmental Health Association

Show Dates: June 22-23, 2008

Show Location: Presidio & Turquoise Ballrooms

Deadline Date To Receive Discounted Rates: June 9, 2008

EXHIBITOR MOVE-IN

SUNDAY JUNE 22, 2008 1:00 PM - 5:00 PM

SHOW HOURS

SUNDAY JUNE 22, 2008 6:00 PM - 9:00 PM

MONDAY JUNE 23, 2008 8:00 AM - 2:00 PM

EXHIBITOR MOVE-OUT

MONDAY JUNE 23, 2008 2:00 PM - 6:00 PM

Move-Out Note: All carriers must check in no later than 3:30 PM on TUESDAY, JUNE 24, 2008 or freight will be shipped C.O.D. via LibertyCFS co/ Roadway Express.

STANDARD BOOTH EQUIPMENT:

Each 8' X 10' booth space will be provided with an 8' GOLD and HUNTER GREEN background drape and 42' GOLD side divider drapes, 1 - 6' BLACK draped table, 2 side chairs, wastebasket and booth ID sign.

CARPET COLOR:

The booth area is and the aisles will be carpeted in HOTEL MULTI-COLORED carpet.

ADVANCE WAREHOUSE:

Exhibiting Company Name / Booth Number
NATIONAL ENVIRONMENTAL HEALTH ASSOCIATION
c/o LibertyCFS c/o Roadway Express
c/o AEX Convention Services
601 W. Flores Street
Tucson, AZ 85705

Materials should be shipped to ARRIVE at our warehouse **NO LATER THAN MONDAY, JUNE 16, 2008** Shipments will not be accepted any earlier than Thursday, May 22, 2008.

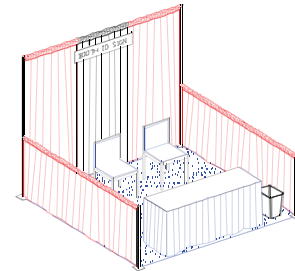

DIRECTLY TO FACILITY:

Hilton, El Conquistador, Tucson, AZ
National Environmental Health Association
Exhibiting Company Name / Booth Number
c/o AEX Convention Services
10000 N. Oracle Road
Tucson, AZ 85704

Shipments will be received at the exhibit facility on: SUNDAY, JUNE 22, 2008 Between 1:00 PM - 5:00 PM

AEX



Official Suppliers

Show Name: National Environmental Health Association

Show Dates: June 22-23, 2008

Deadline Date To Receive Discounted Rates: June 9, 2008

AEX CONVENTION SERVICES

Administrative Offices
3089 English Creek Ave.
Egg Harbor Twp., NJ 08234
Phone: (609) 272-1600
Fax: (609) 272-1680
www.aexservices.com

ADVANCE WAREHOUSE

LibertyCFS c/o Roadway Express
601 W. Flores Street
Tucson, AZ 85705
Contact: Bob Doyle
Phone: (520) 624-7432

AIR, GROUND & VAN LINE

FREIGHT SERVICES

LibertyCFS c/o Roadway Express
Phone: (905) 338-3993
Fax: (905) 338-1092

AUDIO/VISUAL

RENTAL SERVICES

3089 English Creek Ave.
Egg Harbor Twp., AZ 08234
For assistance please call:
Phone (609) 272-1600
Fax: (609) 272-1680
Please mail or fax forms to AEX Convention Services.

SHOW MANAGEMENT

National Environmental Health Association
720 So. Colorado, Blvd., Suite 1000-N
Denver, CO 80246
Phone: (303) 756-9090 Ext. 342

FLORAL SERVICE

AEX Services
Phone: (609) 272-1600

SPECIALTY FURNITURE SERVICE

AEX Convention Services
Phone: (609) 272-1600

**TELEPHONE SERVICE
ELECTRICAL SERVICE**

Hilton El Conquistador
10000 N. Oracle Road
Tucson, AZ 85704
Phone: (520) 544-1125
Fax: (520) 544-1227



Limits and Liabilities

LIMITS & LIABILITIES AND TERMS AND CONDITIONS BY USING OUR SERVICES OR SIGNING THE AGREEMENT TO TERMS AND CONDITIONS, YOU AND YOUR COMPANY AGREE TO THE FOLLOWING

DRAYAGE/FREIGHT RATES APPLY to each pound with a minimum (see front for actual minimum) and are based on the actual or estimated INBOUND weight. No allowance will be made for during the event. Each shipment is considered separately. NO cumulative weights will be allowed on minimums, split shipments, etc.

SHIPMENTS OF EQUIPMENT REQUIRING SPECIAL HANDLING at the facilities will be subject to a surcharge as indicated on the freight rate schedule. This classification shall be applied to, but not limited to, van shipments or shipments which are packed in such a manner as to require unloading by hand (e.g., loose display parts, uncrated equipment, etc.) Material will be unloaded from vans, exhibitor's truck, or trucks of others at the facility, delivered to the Exhibitor's booth, picked up at the close of the show, moved to the loading area and reloaded. The Exhibitor must provide written and accurate weight information on each shipment. Shipments received without Certified Weight Tickets or Bills of Lading, such as UPS or U.S. Mail, will be delivered to the booth without guarantee of piece count or condition. No liability will be assumed for such shipments.

SPECIAL SERVICES AND RATES - Steel banding for the packing of displays and equipment is available at the AEX Convention Services service desk for \$2.00 per linear ft. plus labor at prevailing rates. Forklifts and drivers are available for spotting equipment in the booth at prevailing rates for equipment and labor. Shrink-Wrap is available at a flat rate of \$45.00 per 4x4x4 pallet, thereafter pro-rata.

EMPTY CONTAINER STORAGE - Properly labeled empty containers of freight handled by AEX Convention Services will be removed and returned to the booth; "empty" labels will be available at the service desk. Affixing labels is the sole responsibility of the Exhibitor or representative who must remove or obliterate all old labels. AEX Convention Services assumes no responsibility for removal of containers with old empty storage labels or without AEX Convention Services labels, improper information on empty labels or valuables stored in containers with empty labels. Handling of empty containers of freight not brought in by AEX Convention Services will be charged \$15.00 per box or crate each way.

OUTBOUND SHIPPING INSTRUCTIONS should be given to AEX Convention Services during the event or immediately after its close. All bills of lading and shipping instructions covering outbound shipments will be checked at the time of actual loading and corrections made where discrepancies exist. Freight remaining on the exhibit floor without proper instructions for disposition will be removed by AEX Convention Services and shipped with the information available at the time using a carrier of AEX Convention Service's choice or brought to AEX's warehouse storage and handling will be charged. AEX Convention Services will not be liable for shipping errors subsequent to the event unless it has agreed to specific written instructions has failed to honor them. The condition, count, and contents of the materials found in the booth at the time of actual removal will be final and binding and the right is reserved to alter exhibitor's bill of lading to reflect actual condition, count, and content found.

LIMITATIONS OF LIABILITY - AEX Convention Services IS NOT responsible for damage to materials improperly packed, concealed damage, loss or theft of Exhibitors' material after same has been delivered to your booth, or before materials have been picked up for loading out of the booth. AEX Convention Services makes no warranties or claims except as may be set forth in these terms and conditions. No oral modifications may be made to these terms. Regardless of your claim, AEX Convention Service's liability with respect to your freight or any damage whatsoever, is limited to \$.10 per pound/per article, with a maximum of \$50.00 per item, and a maximum of \$1,000.00 per shipment, even in the event of AEX Convention Service's negligence. AEX's liability for any damages whatsoever when you hire us for supervised installation/dismantle is limited to the actual cost for supervision.

EXHIBIT LOSS OR DISAPPEARANCE - AEX Convention Services and its subcontractors ARE NOT responsible for loss or disappearance of Exhibitor's material after such material has been delivered to the Exhibitor's booth. Relative to inbound shipments, there may be a lapse of time between the delivery of shipment(s) to the applicable booth by AEX Convention Services or its subcontractors, and the arrival of Exhibitor's representative at the booth. During such time the shipment(s) will be left unattended in the booth. AEX Convention Services or its subcontractors shall not be responsible for any loss or damage that may occur during such a period.

Similarly, AEX Convention Services and its subcontractors ARE NOT responsible for loss or disappearance of Exhibitor's material before Exhibitor's material is picked up from the Exhibitor's booth for loading after the exhibition. All bills-of-lading covering outgoing shipment that are given to AEX Convention Services by the Exhibitor will be checked at the time of pick-up from the booth, and corrections will be made at such time if discrepancies exist. Relative to outgoing shipments, it is possible that there will be a lapse of time between the completion of the packing and the pick up material from the booths for loading onto a damage that may occur during such period. AEX Convention Services and its subcontractors are not responsible for any loss or damage that may occur during such period. AEX Convention Services and its subcontractors will adjust the quantities of items on any bill-of-lading submitted to AEX Convention Services or its subcontractors to conform to the actual count of such items in the booth at the time of pick-up and shipment.

DISPUTES - In the event of any dispute between an Exhibitor and AEX Convention Services relative to any loss or damage to such Exhibitor's material, such Exhibitor shall not be entitled to and shall not withhold payment of any amount due to AEX Convention Services for services or rentals provided as any offset against the amount of any alleged loss or damage. Instead, such Exhibitor shall pay AEX Convention Services for any rental or services and Exhibitor may pursue any claim against AEX Convention Services independently. No claims for loss or damage will be considered until payment in full for all services performed by AEX Convention Services has been received.

INSURANCE - Exhibitors agree to carry all-risk floater insurance covering their material against damage, loss, theft and all hazards which covers from the time shipment is made prior to show until shipments are returned to Exhibitor after the show.

We require full payment with order for rentals, service, tax and anticipated freight. This Form, with your credit card information for payment of advance and show site orders, must be completed, mailed or faxed to AEX Convention Services in order for us to provide any rentals or services. Full payment must accompany your order to qualify for the discounted rates. A \$25.00 surcharge will be added to your account if any credit charges are denied or if any checks are returned. Unpaid account will accrue a service charge of 1.5% per month. Exhibitor agrees to be responsible for all fees connected with the collection of its accounts.



EAC/Third Party Billing

Please Mail or Fax Completed Form to: AEX Convention Services
 3089 English Creek Ave., Egg Harbor Township, NJ 08234
 Fax: (609) 272-1680 • Phone: (609) 272-1600
www.aexservices.com

Show Name: **National Environmental Health Association**

Show Dates: **June 22-23, 2008**

Deadline Date To Receive Discounted Rates: June 9, 2008

To: AEX Services

Please be advised that we will be using an independent contractor of our own choosing to perform installation/dismantle labor services at the Hilton El Conquistador, Tucson, AZ. We are aware that a responsible representative of our contractor must report to the AEX Service Desk on the first day of set-up. No badges will be issued until all pertinent paperwork is in order.

Third Party/Display House:

Address: _____

City : _____ State: _____ Zip: _____

Contact: _____

Phone Number: _____ Booth Number: _____

Your Name: _____ Your Signature: _____

Date: _____

Display house must also provide a Certificate of Insurance to AEX

	Exhibitor will pay	Third Party will pay	
Furniture	<input type="radio"/>	<input type="radio"/>	\$ _____
Carpet	<input type="radio"/>	<input type="radio"/>	\$ _____
Labor	<input type="radio"/>	<input type="radio"/>	\$ _____
Cleaning	<input type="radio"/>	<input type="radio"/>	\$ _____
Freight	<input type="radio"/>	<input type="radio"/>	\$ _____
Utilities	<input type="radio"/>	<input type="radio"/>	\$ _____
Other Services	<input type="radio"/>	<input type="radio"/>	\$ _____

Acceptance of this third party billing is contingent upon:

An Authorization Form, the Insurance Form and return of the notification letter prior to the deadline date.

Company Name: _____ **Booth#:** _____



FURNITURE RENTAL ORDER FORM

Please Mail or Fax Completed Form to: AEX Convention Services
 3089 English Creek Ave., Egg Harbor Township, NJ 08234
 Fax: (609) 272-1680 • Phone: (609) 272-1600
www.aexservices.com

Show Name: **National Environmental Health Association**

Show Dates: **June 22-23, 2008**

Deadline Date To Receive Discounted Rates: **June 9, 2008**

FURNITURE

Description	Discount	Standard	Qty.	Total
Plastic Side Chair	\$37.75	\$53.25	_____	_____
Padded Arm Chair	\$53.75	\$75.00	_____	_____
Deluxe Padded Arm Chair	\$66.50	\$93.00	_____	_____
Padded Counter Stool	\$58.75	\$82.25	_____	_____
Cocktail Table 18"H	\$66.00	\$93.50	_____	_____
Cocktail Table 30"H	\$80.75	\$113.25	_____	_____
Cocktail Table 42"H	\$95.00	\$133.25	_____	_____
Literature Rack	\$160.25	\$224.50	_____	_____
Security Cage	\$255.00	\$357.00	_____	_____
Wastebasket	\$16.00	\$22.50	_____	_____
Easel	\$39.50	\$55.25	_____	_____
Chrome Sign Frame (24" x 28")	\$46.00	\$64.50	_____	_____
Waterfall Bag Rack	\$41.00	\$57.25	_____	_____
Chrome Stanchion	\$43.00	\$60.25	_____	_____
Chrome Bag Holder	\$43.00	\$60.25	_____	_____
Chrome Clothes Tree	\$43.00	\$60.25	_____	_____
White/Silver Plastic Chain(/ft.)	\$6.75	\$9.75	_____	_____
Crossbar	\$18.50	\$26.25	_____	_____
Upright with Base	\$23.00	\$32.25	_____	_____

DISPLAY TABLES (Price includes top covered with white plastic and 3 sides draped)

Description	Discount	Standard	Qty.	Total
4'L x 24"W x 30"H	\$88.25	\$124.00	_____	_____
4'L x 24"W x 42"H	\$118.50	\$165.75	_____	_____
6'L x 24"W x 30"H	\$106.75	\$150.50	_____	_____
6'L x 30"W x 30"H	\$126.50	\$177.50	_____	_____
6'L x 24"W x 42"H	\$137.75	\$193.00	_____	_____
6'L x 30"W x 42"H	\$177.50	\$249.00	_____	_____
8'L x 24"W x 30"H	\$123.50	\$173.00	_____	_____
8'L x 30"W x 30"H	\$147.00	\$206.75	_____	_____
8'L x 24"W x 42"H	\$154.25	\$215.75	_____	_____
8'L x 30"W x 42"H	\$177.50	\$249.00	_____	_____
4th Side Drap 30"	\$40.00	\$56.25	_____	_____
4th Side Drap 42"	\$45.50	\$63.75	_____	_____

Please select color:

- Burgundy
- Blue
- Teal
- Black
- Purple
- Gray
- Gold
- Green
- White

Undraped Tables are 25% off of draped rate. (Circle size above)

TABLETOP RISERS -12"w x 8"h (Covered in white plastic)

Description	Discount	Standard.	Qty.	Total
4' Long, Single Step	\$42.00	\$58.75	_____	_____
6' Long, Single Step	\$53.75	\$75.00	_____	_____

Uncovered Risers are 25% off of the draped rate. (Circle size above)

DRAPES (Drape rates are per linear foot)

Description	Discount	Standard	Qty.	Total
8' Background Drap / lin. ft.	\$16.00	\$22.50	_____	_____
Side Rail Drap 42" h. / lin. ft.	\$12.25	\$17.50	_____	_____

Please select color:

(For background & side rail drap only)

- Burgundy
- Blue
- Teal
- Black
- Purple
- Gray
- Gold
- Green
- White

FURNITURE ORDER TOTAL: \$ _____



Company Name: _____ Booth#: _____

YES, I have completed and enclosed the Authorization and Agreement to Terms and Conditions Form and I understand that all orders are subject to Arizona State Sales tax 8.1%.

Show Name: National Environmental Health Association

Show Dates: June 22-23, 2008

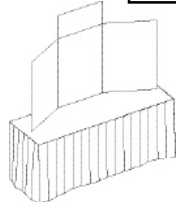
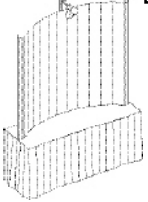
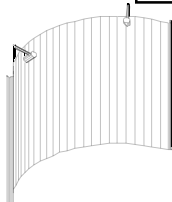
Deadline Date To Receive Discounted Rates: June 9, 2008

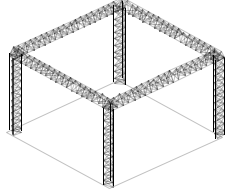
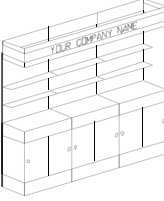
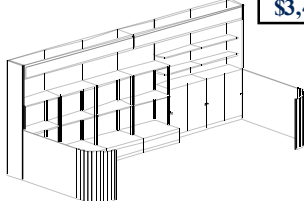
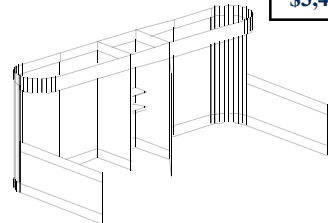
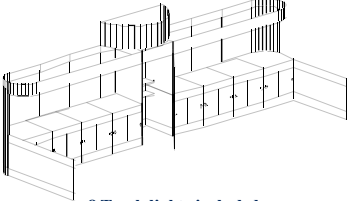
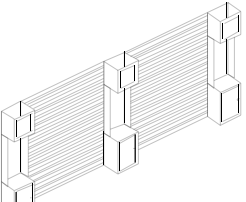
<p>(#1) Panel Tabletop</p> <p>\$316.00</p>  <p>6' wide x 36" high tabletop unit in silver. Velcro compatible</p>	<p>(#2) Curved Tabletop Pop-up</p> <p>\$505.00</p>  <p>6' wide x 64" high tabletop unit in silver. Velcro compatible with 1 spotlight</p>	<p>(#3) Pop-up Display</p> <p>\$959.00</p>  <p>16' wide x 8' compatible with 2 spotlights</p>	<p>(#4) 10' x 10' Hard wall Unit</p> <p>\$1,708.50</p>  <p>3 Track lights included</p>
<p>(#5) 20' x 20' Truss Unit</p> <p>\$4,488.00</p>  <p>Truss Exhibit available in various sizes</p>	<p>(#6) 10' x 10' Counter Exhibit</p> <p>\$1,815.75</p>  <p>3 Track lights included</p>	<p>(#7) 10' x 20' Shelf Unit</p> <p>\$3,422.25</p>  <p>6 Track lights included</p>	
<p>(#8) 10' x 20' Curved Exhibit</p> <p>\$3,422.25</p>  <p>6 Track lights included</p>	<p>(#9) 10' x 30' Curved Exhibit</p> <p>\$4,819.50</p>  <p>8 Track lights included</p>	<p>(#10) 10' x 20' Professional Exhibit</p> <p>\$4,488.00</p>  <p>3 Lights boxes, 3 Locking counters, Slatwall. Professionally Black Laminated</p>	

NOTE: Above prices include delivery, installation and removal. Please see our Furniture and Carpet Rental Order Forms if you would like to order carpet or furniture.

- ❖ **Additional Lights** Qty. _____ Light @ \$64.75 each = \$ _____
- ❖ **Additional Hardware Shelves** Qty. _____ Shelves @ \$32.25 each = \$ _____
- ❖ **Aluminum Slatwall Per Panel** Qty. _____ Slatwall @ \$107.25 each = \$ _____
- ❖ **Units 4, 6, 7, 8, & 9 are provided in white hard wall unless colored or Velcro compatible panels are ordered.**
- Red ○ Blue ○ Black ○ Gray Qty. _____ Colored panels @ \$10.75 each = \$ _____
- Qty. _____ Velcro panels @ \$27.25 each = \$ _____
- ❖ **Matching counters 42"H x 21"L x 40"W** Qty. _____ Counters @ \$123.25 each = \$ _____

❖ Please call to discuss your sign requirements and pricing. Standard signage is black letters on a white background.

PRINT SIGN TEXT ON A SEPARATE SHEET:

- ❖ If you require a Custom Exhibit Design not shown above, please call (609) 272-1600
- ❖ Electric service IS NOT included. Please make arrangements in advance with exhibit facility.

Company Name: _____ Booth#: _____
 Unit# _____ Unit Price \$ _____

Add 30% if ordered after deadline \$ _____

SUBTOTAL, MODULAR EXHIBIT RENTAL ORDER \$ _____

YES, I have completed and enclosed the Authorization and Agreement to Terms and Conditions Form and I understand that all orders are subject to Arizona State Sales tax 8.1%.



CARPET RENTAL ORDER FORM

Please Mail or Fax Completed Form to: AEX Convention Services
 3089 English Creek Ave., Egg Harbor Township, NJ 08234
 Fax: (609) 272-1680 • Phone: (609) 272-1600

www.aexservices.com

Show Name: National Environmental Health Association

Show Dates: June 22-23, 2008

Deadline Date To Receive Discounted Rates: June 9, 2008

STANDARD BOOTH CARPET (Standard booth carpet is not available for Island Booths. Please see the Cut & Lay carpet below.)

Description	Discount	Standard	Total	Please select color:		
9'x 10'	\$117.00	\$164.00	\$ _____	<input type="radio"/> Black	<input type="radio"/> Gray	<input type="radio"/> Burgundy
9'x 20'	\$234.00	\$327.00	\$ _____	<input type="radio"/> Teal	<input type="radio"/> Purple	<input type="radio"/> Green
9'x 30'	\$351.00	\$491.50	\$ _____	<input type="radio"/> Blue	<input type="radio"/> Red	<input type="radio"/> Lime Green
9'x 40'	\$468.00	\$655.25	\$ _____			

Over 9'x 40' available pro rata.

This carpet is not designed to cover complete booth areas since the rental cost does not include seaming and the carpets are not guaranteed to be a color match. If complete exhibit area carpet is desired, see cut & lay section below.

- Add padding with the purchase of Rental Carpet for \$50.00 per 10'x 10' booth space.
- Add protective plastic covering with the purchase of Rental Carpet for \$40.00 per 10'x 10' booth space.

Number of 10'x 10' Booth Space(s) _____ x \$50.00 = _____

Number of 10'x 10' Booth Space(s) _____ x \$40.00 = _____

CUT & LAY CARPET (100 sq. ft. Minimum Order)

Complete Area Size: _____ Ft. x _____ Ft. = _____ Sq. Ft. @

Discount	Standard
\$2.75/sq.ft.	\$3.75/sq.ft. = \$ _____

- Please select color:**
- Black
 - Gray
 - Burgundy
 - Teal
 - Purple
 - Green
 - Blue
 - Red
 - Lime Green

DECORATIONS PLUSH CARPET (Subject to availability)

Complete Area Size: _____ Ft. x _____ Ft. = _____ Sq. Ft. @

Description	Discount	Standard
34 oz.	\$4.25/sq.ft.	\$6.25/sq.ft. = \$ _____
50 oz.	\$5.75/sq.ft.	\$8.25/sq.ft. = \$ _____

- Please select color:**
- Dusty Rose
 - Light Teal
 - Toast
 - Ivory
 - Cream
 - Sandstone
 - Baby Blue
 - Sky Blue
 - Navy
 - Misty Gray
 - Silver Mist
 - Gun Metal
 - Cherry Red
 - Burgundy
 - Ebony
 - Forest Green

Order must be received at least four weeks prior to the show.
 Custom carpet is a luxurious 34 oz. Or 50 oz. Carpet available in assorted decorator colors.
 Swatches will be sent to you upon your request. Minimum order for decorators plush carpet is 200 sq. ft.

(All prices include installation and removal) SUBTOTAL CARPET RENTAL ORDER: \$ _____

YES, I have completed and enclosed the Authorization and Agreement to Terms and Conditions Form and I understand that all orders are subject to Arizona State Sales tax 8.1%.

Company Name: _____ Booth#: _____

Please Mail or Fax Completed Form to: AEX Convention Services
 3089 English Creek Ave., Egg Harbor Township, NJ 08234
 Fax: (609) 272-1680 • Phone: (609) 272-1600

www.aexservices.com

Show Name: **National Environmental Health Association**

Show Dates: **June 22-23, 2008**

Deadline Date To Receive Discounted Rates: **June 9, 2008**

GRID WALL

Each Panel is 2'x 8' with a 3"x 3" grid.
 At least two panels are needed to be free standing without the use of feet.
 Feet must be rented to have individual (2'x 8') free standing units.
 Feet are supplied attached to each free standing unit.

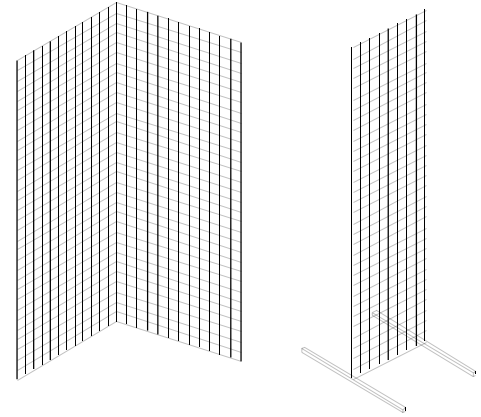

Description	Discount	Standard		Total
_____ 2'x 8'	\$70.25	\$98.25	each =	\$ _____
_____ Pair of feet	\$28.25	\$39.50	each =	\$ _____

WHITE PERF BOARD (Shown Below)

WHITE TACK BOARD

Complete Area Size: _____ Ft. x _____ Ft. x _____ Sq. Ft. @

Description	Discount	Standard	Qty.	Total
Style A - 2'w x 8'h Panel	\$91.00	\$127.50	_____	\$ _____
Style A - 4'w x 8'h Panel	\$132.75	\$185.75	_____	\$ _____
Style B - 8'w x 2'h Panel	\$91.00	\$127.50	_____	\$ _____
Style B - 8'w x 4'h Panel	\$132.75	\$185.75	_____	\$ _____
Style C - 10'w x 8'h Panel	\$608.00	\$850.25	_____	\$ _____
Perf Board Shelving 4' long	\$28.25	\$39.50	_____	\$ _____

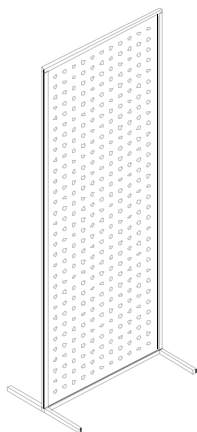

Style A
Vertical to Floor

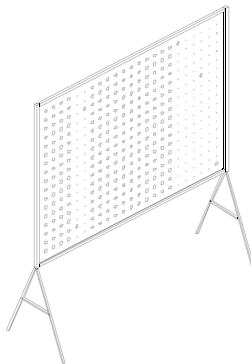

Style B
Horizontal off Floor
(3" Off the Floor)

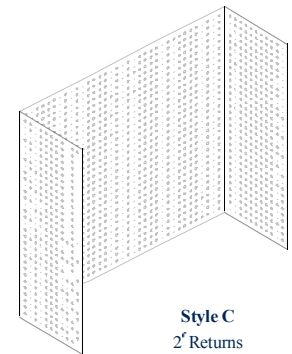

Style C
2' Returns

SUBTOTAL GRID WALL, PERF BOARD & TACK BOARD ORDER: \$ _____

YES, I have completed and enclosed the Authorization and Agreement to Terms and Conditions Form and I understand that all orders are subject to Arizona State Sales tax 8.1%.

Company Name: _____ Booth#: _____



SHOWCASE RENTAL ORDER FORM

Please Mail or Fax Completed Form to: AEX Convention Services
 3089 English Creek Ave., Egg Harbor Township, NJ 08234
 Fax: (609) 272-1680 • Phone: (609) 272-1600

www.aexservices.com

Show Name: National Environmental Health Association

Show Dates: June 22-23, 2008

Deadline Date To Receive Discounted Rates: June 9, 2008

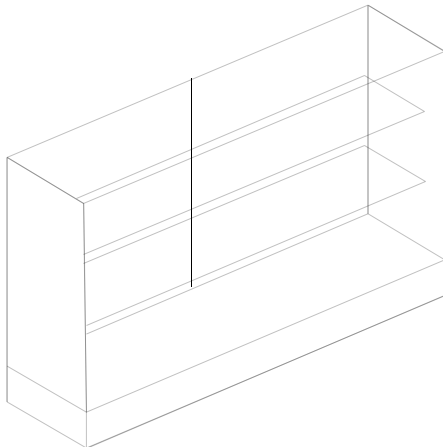

EXTRA VISION SHOWCASE
(Thin Aluminum Frame)

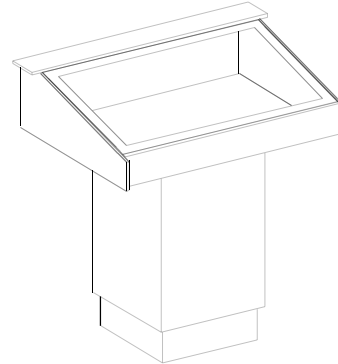

TOPVISION SHOW CASE

Glass shelves are used in these items. To prevent breakage of shelves and articles, good judgement must be used during installation and loading of glass shelves. Take care in placing heavy items or large quantities of items on these glass shelves. A sudden shock, even from small items dropped, can result in broken glass causing personal injury as well as loss of treasured valuables. AEX Convention Services does not assume responsibility for broken glass and/or personal valuables. Rental price includes delivery to and removal from your booth space.

PLEASE MAKE YOUR SELECTION BELOW

Type	Qty.	Discount	Standard	Total
Extra Vision Showcase 38"H x 20"D x 70"	_____	\$402.00	\$563.75	_____
Top Vision Showcase 49"H x 39"D x 43"	_____	\$357.00	\$500.00	_____
Additional Shelves	_____	\$26.25	\$36.75	_____
Locks	_____	\$24.00	\$33.75	_____

Electrical Orders must be placed with the **ELECTRICAL SERVICE FORM**

ALL ORDERS ARE SUBJECT TO AVAILABILITY.
 ADDITIONAL CASES AVAILABLE UPON REQUEST, PLEASE CALL.

SUBTOTAL SHOWCASE RENTAL ORDER: \$ _____

YES, I have completed and enclosed the Authorization and Agreement to Terms and Conditions Form and I understand that all orders are subject to Arizona State Sales tax 8.1%.

Company Name: _____ Booth#: _____



MATERIAL HANDLING ORDER FORM

Please Mail or Fax Completed Form to: AEX Convention Services
 3089 English Creek Ave., Egg Harbor Township, NJ 08234
 Fax: (609) 272-1680 • Phone: (609) 272-1600
www.aexservices.com

Show Name: National Environmental Health Association

Show Dates: June 22-23, 2008

Deadline Date To Receive Discounted Rates: June 9, 2008

**MATERIAL HANDLING RATES - ROUND-TRIP RATES, PER SHIPMENT, USE INCOMING WEIGHT ONLY AND ROUND UP TO THE NEXT 100 LBS. THESE RATES ARE SUBJECT TO SURCHARGE (See Below).
 SHIPMENTS RECEIVED WITHOUT BILLS OF LADING, SUCH AS UPS OR FED EX WILL BE DELIVERED TO THE BOOTH WITHOUT GUARANTEE OF PIECE COUNT OR CONDITION.
 CERTIFIED WEIGHT TICKETS ARE REQUIRED FOR EACH SHIPMENT, IF NOT PROVIDED, YOU AGREE TO USE AEX CONVENTION SERVICES' ESTIMATED WEIGHTS.**

RATE PER 100 LBS. (200 L.B. MIN.)

(CWT - 100 lbs.)

Description	Receiving	S.T. In / S.T. Out	Overtime In or Out	O.T. In / O.T. Out
A1 - ON TIME Crated or Skidded shipments (LTL Carriers with established local terminals)	Advance Warehouse	\$63.00 per cwt. \$126.00 minimum	\$94.50 per cwt. \$189.00 minimum	\$141.75 per cwt. \$283.50 minimum
A2 - VAN LINES (Irregular route carrier)	Advance Warehouse	\$94.50 per cwt. \$189.00 minimum	\$141.75 per cwt. \$283.50 minimum	\$212.75 per cwt. \$425.50 minimum
B1 - ON TIME Crated or Skidded shipments (LTL Carriers with established local terminals)	Convention Site	\$63.00 per cwt. \$126.00 minimum	\$94.50 per cwt. \$189.00 minimum	\$141.75 per cwt. \$283.50 minimum
B2 - VAN LINES and loose and uncrated shipments (Irregular route carrier)	Convention Site	\$94.50 per cwt. \$189.00 minimum	\$141.75 per cwt. \$283.50 minimum	\$212.75 per cwt. \$425.50 minimum

(S.T. = Straight Time / O.T. =Overtime)

A Transfer fee of \$125.00 + \$12.00 per cwt. for each week of storage will apply for all shipments going to AEX Convention Service's Warehouse to be picked up by outside carriers or shipped to other events. This fee of \$125.00 will apply for all shipments going to AEX Convention Services Warehouse to be shipped via UPS (AEX's account only).

Overtime Rates will apply if:

- Inbound vehicles arrive at the dock weekdays prior to 8:00 AM or after 3:00 PM or anytime Saturday, Sunday and Holidays
- Outbound vehicles are loaded weekdays prior to 8:00 AM or after 3:00 PM or anytime Saturday, Sunday and Holidays.
- Warehouse freight is moved to the event floor on overtime due to scheduling.

A 50% surcharge will apply if: freight is received after the "last day accepted" for Advance warehouse shipments or outside indicated times to the convention site.

Estimated charges for material handling..... $\frac{\text{Estimated Weight}}{\text{Estimated Rate}} \text{ lbs.} \times \frac{\text{Estimated Rate}}{\text{Total Estimated Material Handling}} \text{ per cwt.} = \$$ _____

SUBTOTAL MATERIAL HANDLING ORDER: \$ _____

YES, I have completed and enclosed the Authorization and Agreement to Terms and Conditions Form and I understand that all orders are subject to Arizona State Sales tax 8.1%.



ADVANCE WAREHOUSE SHIPPING

Show Name: National Environmental Health Association

Show Dates: June 22-23, 2008

ADVANCE WAREHOUSE SHIPPING

TRADE SHOW SHIPMENT - PLEASE EXPEDITE

To: _____
Name of Exhibitor

Booth: _____

**NATIONAL ENVIRONMENTAL
HEALTH ASSOCIATION
c/o LibertyCFS c/o Roadway Express
c/o AEX Convention Services
601 W. Flores Street
Tucson, AZ 85705**

Deliver NO LATER than **MONDAY, JUNE 16, 2008**

Receiving 9AM-2PM, Monday-Friday
Check In by 2PM



DIRECT SHIPMENT

Show Name: National Environmental Health Association

Show Dates: June 22-23, 2008

DIRECT SHIPMENT TO THE FACILITY

TRADE SHOW SHIPMENT - PLEASE EXPEDITE

To: _____

Name of Exhibitor

Booth: _____

**HILTON EL CONQUISTADOR, TUSCON, AZ
NATIONAL ENVIRONMENTAL HEALTH ASSOCIATION
C/O AEX CONVENTION SERVICES
10000 N. ORACLE RD.
TUCSON, AZ 85704**

Deliver ON: SUNDAY, JUNE 22, 2008

Between 1:00 PM - 5:00 PM





LABOR SERVICE FORM

Please Mail or Fax Completed Form to: AEX Convention Services
 3089 English Creek Ave., Egg Harbor Township, NJ 08234
 Fax: (609) 272-1680 • Phone: (609) 272-1600
www.aexservices.com

Show Name: National Environmental Health Association

Show Dates: June 22-23, 2008

Deadline Date To Receive Discounted Rates: June 9, 2008

PLAN A: PROFESSIONALLY SUPERVISED INSTALLATION AND DISMANTLING (see next page for important shipping information)

LET US DO THE WORK FOR YOU - YOU WALK AWAY!

- Supervision by our professionals
- Installation and dismantling by experienced laborers
- Materials prepared for shipment to next destination
- Empties stored during event
- Shipping labels provided

Please forward detailed instructions, blueprints or photos and complete the information on the back of this form. Our cost for this service is 35% of your total labor bill (\$35.00 minimum). This service provides our expert supervision and saves the expense and productive time of your own personnel. Please note: Our liability for damages, for whatever reason, is limited to our billed cost for supervision.

PLAN B: EXHIBITOR'S SUPERVISION

- Installation and dismantling by experienced laborers
- Empties stored during event

For those using Plan B, on the day and time that you have requested labor, please report to the AEX Convention Services Desk to pick-up and sign out your labor crew. You will be charged a one hour minimum per laborer ordered if you do not report to the Service Desk at the time you have requested labor. The labor crew will not be sent to your booth without being signed out. Upon completion of their work, you are required to accompany the laborers back to the AEX Convention Services Desk and sign them in. All exhibitors ordering labor will be billed a one-hour minimum for each person ordered unless a written cancellation order is received by 11:00 am the day before the labor is supplied. It is not necessary to order labor for unloading freight (see Material Handling Order Form). ALL WORK IS DONE ONLY UNDER THE SUPERVISION OF THE EXHIBITOR'S REPRESENTATIVE.

LABOR RATES: 1 HOUR MINIMUM PER PERSON, 1 HOUR INCREMENTS THEREAFTER
PLEASE NOTE: LIGHTS, ELECTRIC MOTORS AND OTHER ELECTRICAL COMPONENTS REQUIRE THE USE OF ELECTRICIAN LABOR. IF NECESSARY, YOU WILL BE CHARGED ACCORDINGLY.

	Discount	Standard
<u>Straight Time</u> (Monday through Friday between 8 am - 4:30 pm)	\$75.00 per hour	\$105.25 per hour
<u>Overtime</u> (Monday through Friday before 8 am and after 4:30 pm and anytime Saturday or Sunday)	\$112.50 per hour	\$157.25 per hour
<u>Double Time</u> (Anytime on Holidays)	\$150.00 per hour	\$209.25 per hour

Starting time can be guaranteed only in those instances where workers are requested for the start of published move-in times (usually 8:00 am). Please indicate service desired by checking either Plan A or Plan B. If no plan is indicated, labor cannot be assigned until exhibitor's representative reports to the service desk.

	Estimated Hours	Start Date	Start Time	Estimated Finished Time	# of Laborers	Rate	AEX Supervision	Estimated Total Cost
Installation								
Dismantle								

Dismantle - you will be charged for the same estimated hours and number of laborers for dismantle. In the event less chargeable time is used, we will credit you following the close of the show. All labor provided at show site but not ordered in advance will be charged at the standard rate.

SUBTOTAL ESTIMATED LABOR SERVICE ORDER: \$ _____

YES, I have completed and enclosed the Authorization and Agreement to Terms and Conditions Form and I understand that all orders are subject to Arizona State Sales tax 8.1%.

Company Name: _____ Booth#: _____



SUPERVISED INSTALLATION AND DISMANTLE INFORMATION SHEET

Please Mail or Fax Completed Form to: AEX Convention Services
3089 English Creek Ave., Egg Harbor Township, NJ 08234
Fax: (609) 272-1680 • Phone: (609) 272-1600

www.aexservices.com

Show Name: National Environmental Health Association

Show Dates: June 22-23, 2008

Deadline Date To Receive Discounted Rates: June 9, 2008

Print Your Company Name: _____

Booth# _____

COMPLETE THIS FORM ONLY IF YOU HAVE SELECTED Plan A: Professionally Supervised Installation and Dismantle

This information is required in order to ensure proper supervision and installation of your display.

Freight is arriving at Warehouse Show Site Loading Dock

Date Shipped: _____ Via: _____ (freight carrier)

Display shipped from: _____ (address)

of Crates: _____ # of Cartons: _____ Estimated Weight: _____

Display Includes: _____

Booth carpet in shipment? Yes No

Set-up instructions: Attached to this order With display

RETURN SHIPPING:

Return Display to the following address:

Via: _____ (carrier)



EMERGENCY CONTACT AT SHOW SITE:

Name: _____ Arrival Date: _____

Hotel: _____ Telephone: _____

Company Name: _____ Booth#: _____



FORKLIFT AND RIGGING CREW ORDER FORM

Please Mail or Fax Completed Form to: AEX Convention Services
3089 English Creek Ave., Egg Harbor Township, NJ 08234
Fax: (609) 272-1680 • Phone: (609) 272-1600
www.aexservices.com

Show Name: National Environmental Health Association

Show Dates: June 22-23, 2008

Deadline Date To Receive Discounted Rates: June 9, 2008

**ONLY USE THIS FORM IF HEAVY OR LARGE ITEMS THAT MUST BE EXACTLY PLACED
WITHIN YOUR EXHIBIT WITH THE USE OF A FORKLIFT**

(e.g. large header signs, cantilever structures, heavy display components or machinery which cannot be manually lifted in place)

Please complete the Material Handling Form for unloading and moving freight to your booth.

ORDER FOR FORKLIFT AND RIGGING CREW

A Rigging Crew consists of a fork lift, operator, rigger and helper.

PLAN A: PROFESSIONALLY SUPERVISED INSTALLATION AND DISMANTLING (see next page for important shipping information)

LET US DO THE WORK FOR YOU - YOU WALK AWAY!

- Supervision by our professionals
- Empties stored during event
- Installation and dismantling by experienced laborers
- Shipping labels provided
- Materials prepared for shipment to next destination

All work is done under the direction of AEX Convention Services. Our charge for this service is 35% of your total labor bill. This service provides our expert supervision and saves the expense and productive time of your own personnel.

Please note: Our liability for damages, for whatever reason, is limited to our bill cost for supervision.

PLAN B: EXHIBITOR'S SUPERVISION

- Installation and dismantling by experienced laborers
- Empties stored during event

For those using Plan B, on the day and time that you have requested labor, please report to the AEX Convention Services Desk to pick-up and sign out your labor crew. You will be charged a one hour minimum per crew ordered if you do not report to the Service Desk at the time you have requested labor. The labor crew will not be sent to your booth without being signed out. Upon completion of their work, you are required to accompany the laborers back to the AEX Convention Services Desk and sign them in. All exhibitors ordering labor will be billed a one-hour minimum for each person ordered unless a written cancellation order is received by 11:00 am the day before the labor is supplied. It is not necessary to order labor for unloading freight (see Material Handling Order Form). **ALL WORK IS DONE ONLY UNDER THE SUPERVISION OF THE EXHIBITOR'S REPRESENTATIVE.**

LABOR RATES: 1 HOUR MINIMUM PER CREW, 1 HOUR INCREMENTS THEREAFTER

Straight time (8:00 am to 4:30 pm, Monday through Friday):

Overtime (Anytime Saturday or Sunday and Weekdays 4:30 pm to 8:00 am):

Double Overtime (Anytime on Holidays):

Discount	Standard
\$281.75 hr/crew	\$367.25 hr/crew
\$421.50 hr/crew	\$589.75 hr/crew
\$562.25 hr/crew	\$786.50 hr/crew

Starting time can be guaranteed only in those instances where workers are requested for the start of the working day (8:00 am). Please indicate service desired by checking either Plan A or Plan B. If no plan is indicated, labor cannot be assigned until exhibitor's representative reports to the service desk.

	# of Rigging Crews	Start Date	Start Time	Estimated Finished Time	Estimated Hours	Rate	AEX Supervision	Estimated Total Cost
Installation							35%	
Dismantle								

Dismantle - you will be charged for the same estimated hours and number of laborers for dismantle. In the event less chargeable time is used, we will credit you following the close of the show.

SUBTOTAL ESTIMATED FORKLIFT AND RIGGING CREW ORDER: \$ _____

YES, I have completed and enclosed the Authorization and Agreement to Terms and Conditions Form and I understand that all orders are subject to Arizona State Sales tax 8.1%.

Company Name: _____ **Booth#:** _____



OVERHEAD SIGN HANGING

Please Mail or Fax Completed Form to: AEX Convention Services
 3089 English Creek Ave., Egg Harbor Township, NJ 08234
 Fax: (609) 272-1680 • Phone: (609) 272-1600
www.aexservices.com

Show Name: **National Environmental Health Association**

Show Dates: **June 22-23, 2008**

Deadline Date To Receive Discounted Rates: **June 9, 2008**

USE THIS FORM TO ORDER LABOR FOR HANGING SIGNS & BANNERS FROM CEILING

AEX Convention Services reserves the right to assemble, install and dismantle non-electrical "Hanging Signs & Banners" with approved devices and the type of cable needed to safely hand the banner.

- All Signs & Banners will be approved by Show Management, AEX Convention Services and the exhibit facility, prior to hanging.
- All Signs & Banners Hanging Orders must be received by the Deadline Date. Orders received after the deadline or at the Service Desk are subject to availability and a 50% surcharge.
- Complete plans for hanging must be provided and forwarded to AEX Convention Services with this "Overhead Sign Labor Order Form" completed.
- If you sign requires electrical connections, please contact the electrical department for instructions.

THE FOLLOWING INFORMATION MUST BE COMPLETED FOR THE ACCURATE HANGING OF YOUR BANNER:

Date Required: _____
 Type of Sign: Wood Metal Cloth Banner Other _____
 Size of Sign: Height _____ Length _____ Width _____ Weight _____
 Shape of Sign: Square Rectangle Circle Triangle Other _____

NUMBER OF FEET FROM FLOOR TO BOTTOM OF SIGN: _____

All Wire is Hung with 18 Gauge wire

Any signs requiring additional supplies will be billed accordingly.

Please draw dimensions to where you would like your sign, in the box to the left

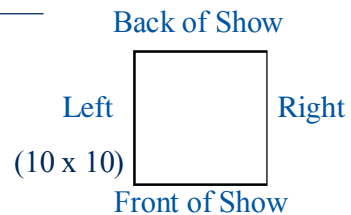

RATES FOR HANGING SIGNS & BANNERS:

Charges are for a 1 hour minimum per crew for installation and a 1 hour minimum charge per crew for dismantle, with billing in 1 hour increments thereafter.

If a Sign or Banner requires assembly, dismantle, installation of supporting devices or hoisting cable, work will be performed on a Time & Material basis.

	Discount	Standard
Straight time (8:00 am to 4:30 pm, Monday through Friday): _____	\$262.25 hr/crew	\$367.25 hr/crew
Overtime (Anytime Saturday or Sunday and Weekdays 4:30 pm to 8:00 am): _____	\$393.75 hr/crew	\$550.25 hr/crew
Double Overtime (Anytime on Holidays): _____	\$525.50 hr/crew	\$735.50 hr/crew

	Start Date	Start Time	Estimated Finished Time	Rate	Estimated Total Cost
Installation					
Dismantle					

SHIPPING:

See "Material Handling Order Form" for shipping addresses and other information.

SUBTOTAL ESTIMATED OVERHEAD SIGN LABOR ORDER: \$ _____

YES, I have completed and enclosed the Authorization and Agreement to Terms and Conditions Form and I understand that all orders are subject to Arizona State Sales tax 8.1%.

Company Name: _____ Booth#: _____



CLEANING SERVICE ORDER FORM

Please Mail or Fax Completed Form to: AEX Convention Services
 3089 English Creek Ave., Egg Harbor Township, NJ 08234
 Fax: (609) 272-1680 • Phone: (609) 272-1600
www.aexservices.com

Show Name: National Environmental Health Association

Show Dates: June 22-23, 2008

Deadline Date To Receive Discounted Rates: June 9, 2008

USE THIS FORM TO ORDER CLEANING SERVICE WITHIN YOUR BOOTH SPACE AND FOR DEBRIS ACCUMULATED DURING SET-UP AND EXHIBIT HOURS.

All rental carpets ordered from AEX Convention Services are installed in clean condition.

VACUUMING / SHAMPOO

All rates are based on the total square footage of your exhibit space (100 sq. ft. minimum)

Please check preference below:

		Discount	Standard
<input type="radio"/>	One Time Vacuum carpet before initial opening of event	\$.36/sq. ft.	\$.50/sq. ft.
<input type="radio"/>	Daily Vacuum carpet before initial opening of event and daily thereafter over 1,000 Ft.	\$.30/sq. ft./day \$.26/sq. ft./day	\$.41/sq. ft./day \$.36/sq. ft./day
<input type="radio"/>	Shampoo Shampoo carpet once (specify day _____)	\$.42/sq. ft./day	\$.58/sq. ft./day

Exhibit Space: _____ ft (x) _____ ft = _____ sq. ft. (x) \$ _____ (x) _____ = \$ _____
(100 sq. ft. minimum) rate per sq. ft. Days Total

PORTER SERVICE

	Discount	Standard
Empty wastebasket, tidy and spot clean exhibit space at two hour intervals during show hours.	\$123.50	\$172.50

Please check preference below:

Daily Once (Specify Day) _____ Date: _____

Porter Service: _____ days (x) amount per day \$ _____

SUBTOTAL ESTIMATED CLEANING ORDER: \$ _____

YES, I have completed and enclosed the Authorization and Agreement to Terms and Conditions Form and I understand that all orders are subject to Arizona State Sales tax 8.1%.

Company Name: _____ Booth#: _____



GRAPHICS ORDER FORM

Please Mail or Fax Completed Form to: AEX Convention Services
 3089 English Creek Ave., Egg Harbor Township, NJ 08234
 Fax: (609) 272-1680 • Phone: (609) 272-1600
www.aexservices.com

Show Name: National Environmental Health Association

Show Dates: June 22-23, 2008

Deadline Date To Receive Discounted Rates: June 9, 2008

Our Experienced Team is committed to providing accurate and professional trade show graphics using the most advanced equipment available.

Trade Show Booth Panels • Banners • Backlits • Posters Signage • POP Displays • Table Drapes • Floor Graphics

Full-Service Graphic Production

Looking for trade show graphics that will get you noticed? Why ship graphic materials to your show? We have full service graphic production capabilities that can meet your design and production needs and deliver the final product right to your booth! We'd be glad to take your graphic order and make it quick, make it easy and, of course, make it big!

For more information call AEX Exhibitor Services at 609-272-1600.

I AM SUPPLYING MY OWN ART ON DISK

I NEED ITEMS DESIGNED. SEE COPY AND LAYOUT SPECS BELOW.

FULL COLOR DIGITAL POSTERS AND COUNTER CARDS

Description	Discount	Standard	Qty.	Total
7" x 11" Counter Card	\$32.75	\$48.25	_____	_____
7" x 44" Counter Card	\$40.00	\$59.25	_____	_____
11" x 14" Counter Card	\$42.50	\$63.25	_____	_____
9" x 44" Poster	\$36.75	\$54.25	_____	_____
14" x 22" Poster	\$51.00	\$77.75	_____	_____
14" x 44" Poster	\$70.50	\$106.25	_____	_____
22" x 28" Poster	\$70.50	\$106.25	_____	_____
26" x 95" Poster on Foamcore	\$154.25	\$234.25	_____	_____
28" x 44" Poster	\$118.50	\$178.50	_____	_____
Easel Back for Counter Card	\$7.25	\$10.25	_____	_____

FULL COLOR DIGITAL BANNERS

Description	Discount	Standard	Qty.	Total
3' x 6'	\$204.00	\$306.00	_____	_____
3' x 8'	\$234.75	\$357.00	_____	_____
4' x 8'	\$270.25	\$406.00	_____	_____
Grommets	\$3.25	\$4.25	_____	_____
Pole Pockets	\$10.25	\$15.50	_____	_____

COPY AND LAYOUT SPECIFICATIONS

Indicate: _____ Vertical or _____ Horizontal (Please attach a layout to this for if necessary)

E-mail address for proofing is required: _____

(Please note: Deadline for requesting a proof is 10 days prior to the first day of installation)

SUBTOTAL GRAPHICS ORDER: \$ _____

YES, I have completed and enclosed the Authorization and Agreement to Terms and Conditions Form and I understand that all orders are subject to Arizona State Sales tax 8.1%.

Company Name: _____ Booth#: _____

AEX maintains a fully-equipped graphics shop that offers: Graphic Design, Large Format Printing, Backlit Graphics, Lamination, Vinyl Graphics, Vinyl Banners. For custom work and quotation, please call Exhibitor Services at 609-272-1600.

* NO GRAPHICS CAN BE ATTACHED TO THE WALLS AT THE Hilton, El Conquistador, Tuscon, AZ*



AUDIO VISUAL ORDER FORM

Please Mail or Fax Completed Form to: AEX Convention Services
 3089 English Creek Ave., Egg Harbor Township, NJ 08234
 Fax: (609) 272-1680 • Phone: (609) 272-1600
www.aexservices.com

Show Name: National Environmental Health Association

Show Dates: June 22-23, 2008

Deadline Date To Receive Discounted Rates: June 9, 2008

If you have a special request or need additional equipment, please call.

	DAILY RATE		Days Used	Qty.	Total
	Advance	On Site			
Video Equipment					
1/2" VHS Player with "end of tape" Repeat	\$70.00	\$98.00	_____	_____	_____
DVD Player	\$111.75	\$156.75	_____	_____	_____
20" Color Monitor, 1/2 VHS Combo Unit	\$139.50	\$195.50	_____	_____	_____
27" Color Monitor (NOT for computer use)	\$98.00	\$137.25	_____	_____	_____
27" Combo Unit (DVD/VHS)	\$280.00	\$392.00	_____	_____	_____
AV Projection Cart	\$21.00	\$30.00	_____	_____	_____
Audio Equipment					
Multi disc CD Player	\$70.00	\$98.00	_____	_____	_____
Wired Microphone: Handheld or Lavalier	\$35.25	\$49.50	_____	_____	_____
Wireless Microphone: Handheld or Lavalier	\$139.25	\$195.50	_____	_____	_____
Powered Speaker w/Stand, (for up to 15 people)	\$56.25	\$78.75	_____	_____	_____
Powered Speaker w/Stand, (for up to 75 people)	\$53.75	\$74.50	_____	_____	_____
Computer Display Equipment					
27" Multi-sync SVGA Monitor	\$288.50	\$396.75	_____	_____	_____
50" Data Projection Monitor	\$557.00	\$779.50	_____	_____	_____
20" Flat Panel Display	\$348.50	\$488.25	_____	_____	_____
32" LCD Flat Panel Display	\$700.00	\$980.00	_____	_____	_____
42" Flat Plasma Display w/ Table or Floor Stand	\$1,253.25	\$1,754.50	_____	_____	_____
50" Flat Plasma Display w/ Table or Floor Stand	\$1,670.25	\$2,339.50	_____	_____	_____
Rental Totals					
Equipment Total	_____	_____	_____	_____	_____
Delivery / Setup / Pickup	_____	_____	_____	_____	\$75.00
Subtotal	_____	_____	_____	_____	_____
Sales Tax (8.1% of line 3)	_____	_____	_____	_____	_____
Total Due	_____	_____	_____	_____	_____

Ordering Instructions:

The total charge per item is determined by multiplying the quantity by the daily rate by the number of rental days.

Make sure to specify each date for rental if you do not need the equipment for the entire show.

Please remember to include \$75.00 delivery charge.

Orders received after the deadline date will be subject to the "Standard" rate.

YES, I have completed and enclosed the Authorization and Agreement to Terms and Conditions Form and I understand that all orders are subject to Arizona State Sales tax 8.1%.

Company Name: _____ Booth#: _____



FLORAL RENTAL ORDER FORM

Please Mail or Fax Completed Form to: AEX Convention Services
 3089 English Creek Ave., Egg Harbor Township, NJ 08234
 Fax: (609) 272-1680 • Phone: (609) 272-1600
www.aexservices.com

Show Name: National Environmental Health Association

Show Dates: June 22-23, 2008

Deadline Date To Receive Discounted Rates: June 9, 2008

SHOW SPECIAL \$150.00

Two 5' Green Plants and fresh floral centerpiece of seasonal flowers
 (Must be ordered by deadline date)

Blooming Potted Plants - Indicate Color Selection

Description	Discount	Standard	Qty.	Total
Azaleas - Available in season	\$37.75	\$53.00	_____	_____
Chrysanthemums - White/Yellow/Bronze/Purple	\$27.00	\$38.25	_____	_____
Other Flowering Plants - Please specify _____	\$38.50	\$53.25	_____	_____

Tropical Green Plants - Indicate Size and Selection

Description	Discount	Standard	Qty.	Total
Ferns - Floor/Hanging	\$38.75	\$54.75	_____	_____
3 Ft. - Slim or Full	\$48.50	\$68.00	_____	_____
4 Ft. - Slim or Full	\$59.25	\$83.25	_____	_____
5 Ft. - Slim or Full	\$80.75	\$113.25	_____	_____
6 Ft. - Slim or Full	\$88.75	\$123.50	_____	_____
7 Ft. - Slim or Full	\$96.50	\$135.25	_____	_____

Flower Arrangements - Indicate Color, Style and Price

Description	Discount	Standard	Qty.	Total
Arrange in Wicker Basket	\$53.75	\$75.00	_____	_____
Vase Arrangement	\$53.75	\$75.00	_____	_____
Centerpiece (Tall, low one side)	\$59.25	\$81.00	_____	_____
Exotic Arrangement (Birds of Paradise, Anthurim, etc.)	\$54.25	\$90.25	_____	_____

Rose Arrangements - Indicate Color, Style and Price

Description	Discount	Standard	Qty.	Total
Color: _____	\$80.75	\$113.25	_____	_____

Balloons

Description	Discount	Standard	Qty.	Total
Mylar Balloons - Indicate Style _____	\$5.75	\$8.25	_____	_____
Latex Balloons - Indicate Color _____	\$3.25	\$4.75	_____	_____

To ensure your floral request, please order no later than 4 days prior to show opening. Orders after that time will be on available basis only.

Due to the seasonal nature of flowers, please indicate your phone number and contact person so that we may confirm your order and let you know what is in season.

Note: Exhibitors are responsible, up to one hour after the published closing time of the show, for safeguarding all rented plants, containers and materials until picked up by a floral representative. Missing material shall be billed to the exhibitor at twice the standard rental fee.

Phone: (____) _____ Contact: _____

SUBTOTAL FLORAL RENTAL ORDER: \$ _____

YES, I have completed and enclosed the Authorization and Agreement to Terms and Conditions Form and I understand that all orders are subject to Arizona State Sales tax 8.1%.

Company Name: _____ Booth#: _____



UNION JURISDICTIONS AND RULES

Show Name: National Environmental Health Association

Show Dates: June 22-23, 2008

Hilton El Conquistador, Tucson, AZ

Trade shows and events held in Hilton, El Conquistador, Tucson, AZ are subject to union jurisdictions that affect exhibitors. You will find the jurisdictions are comparable, and in many cases more user friendly, to other union facilities. This outline is designed to assist you by answering the most frequently asked questions.

Freight & Material Handling

You may ship goods, via the carrier of your choice, to either the advance warehouse or direct to show site for arrival during the published receiving periods. Material Handling (drayage) is within the Decorator's Union jurisdiction (unload, deliver, remove, and reload freight). Material Handling may be ordered using the "Material Handling Order Form" provided in the kit and is entirely distinct from shipping. Exhibitors may handle freight at show site that arrives via their Personally Owned Vehicle (no rental or company vehicle), provided such vehicle is no larger than a 4'x 4' minivan or station wagon, and the freight is hand carried (no dollies, hand trucks, or other wheeled vehicle) to and from your booth.

Furniture & Carpet

Furniture and carpet may be rented using the "Furniture Rental Order Form" and the "Carpet Rental Order Form" which are provided in the kit. The price includes union labor for delivery, installation, and removal.

Booth Erection & Dismantling

Exhibitors may, at their option, erect and dismantle their own booths using their own full-time employees. If their own employees are not available, labor can be ordered using the "Labor Order Form" in the kit. Rigging crews may be hired to move large machinery within booths and can be ordered using the "Forklift & Rigging Crew Order Form" provided in the kit.

Electric

Hilton, El Conquistador, Tucson, AZ Electric Department handles electrical needs, connections and installing powered signs and headers. Their services may be ordered directly from the facility using the form provided in the kit.

Tipping

AEX Convention Services requests that exhibitors do not tip our employees. They are paid an excellent wage scale denoting a professional status, and tipping is not necessary. This applies to all AEX Convention Services employees and its subcontractors.

Safety

Standing on chairs, tables or other rental furniture is prohibited. The furniture is not engineered to support your standing weight. AEX Convention Services is not responsible for injuries caused by improper use of this furniture.

Please assist in our efforts to provide a safe working environment for everyone. If you would like additional information or how the jurisdictions may apply to you and your exhibit, please call AEX Convention Services at (609) 272-1600 for assistance.

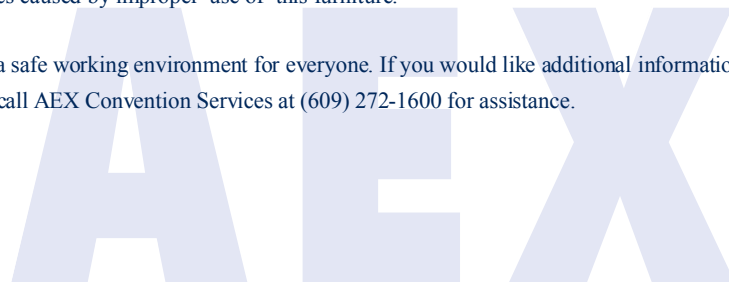

HILTON TUCSON EL CONQUISTADOR ELECTRICAL POWER & EQUIPMENT ORDER

EVENT/SHOW:	BOOTH # or ROOM:
COMPANY NAME:	CONVENTION DATES:
ORDERED BY:	PHONE NUMBER:

ELECTRICAL CURRENT AVAILABLE:
 '1) 120 Volt, A.C. single phase 2) 208 Volt, A.C. single phase 3) 208 Volt, A.C. three phase

ALL CHARGES LISTED ARE BASED ON A 24 HOUR USEAGE

QTY.	ELECTRICAL NEEDS	UNIT COST	EXTENDED AMOUNT	QTY.	EQUIPMENT NEEDS	UNIT COST	EXTENDED AMOUNT
					Distribution pigtail 3-20 Amp outlets	\$ 50.00	\$ -
	20 Amps/120V/1 phase	\$ 30.00	\$ -		Power Strip (15 amp) No Surge Protection	\$ 20.00	\$ -
	20 amps/208V/1 phase	\$ 35.00	\$ -		25 ft. extension cord	\$ 15.00	\$ -
	20 Amps/208V/3 phase	\$ 40.00	\$ -		50 ft. extension cord	\$ 25.00	\$ -
	30 Amps/120V/1 phase	\$ 40.00	\$ -		Cam-Lok - Tee Fittings - Turn Arounds	\$ 15.00	\$ -
	30 Amps/208V/1 phase	\$ 45.00	\$ -		Cam-Lok 50ft. 2/0 cable	\$ 30.00	\$ -
	30 Amps/208V/3 phase	\$ 50.00	\$ -		50 ft. 5 wire extension cord	\$ 65.00	\$ -
	40 Amps/120V/1 phase	\$ 50.00	\$ -		100 ft. 5 wire extension cord	\$ 100.00	\$ -
	40 Amps/208V/1 phase	\$ 55.00	\$ -		Cable protectors 3 foot section	\$ 50.00	\$ -
	40 Amps/208V/3 phase	\$ 60.00	\$ -		Remote lighting dimmer	\$ 75.00	\$ -
	50 Amps/120V/1 phase	\$ 60.00	\$ -		45 KVA transformer 120V/208V/3 phase	\$ 200.00	\$ -
	50 Amps/208V/1 phase	\$ 65.00	\$ -		75 KVA transformer 120V/208V/3 phase	\$ 300.00	\$ -
	50 Amps/208V/3 phase	\$ 70.00	\$ -		Hydraulic Forklift or Forklift	\$ 200.00	\$ -
	See comments regarding additional power				200 AMP 3ph Distribution Box-24cir.	\$ 150.00	\$ -
	Additional power	\$ 30.00	\$ -		100 ft. exhibit cord (12 outlets, 3 circuits)	\$ 100.00	\$ -

We do not stock cord ends for your equipment. Please call in advance to make arrangements for your needs. (520) 544-1730

(A) TOTAL ELECTRICAL CHARGES:	\$	-
(B) TOTAL EQUIPMENT CHARGES:	\$	-
(C) SUBTOTAL A + B:	\$	-
(D) NUMBER OF DAYS: >>>>>		
(E) C x D:	\$	-
(F) LABOR: >>>>> HRS.	\$	-
(G) TOTAL E + F:	\$	-

<p>COMMENTS: Power over 30 AMPS to 100 AMPS single or 3 phase may require the rental of the 45 KVA transformer. Power over 100 AMPS & 200 AMPS single or 3 phase may require the rental of the 75 KVA transformer. Additional electrical charges will apply.</p> <p>Power over 50 AMPS single or 3 phase will have an additional charge of \$30.00 per every 10 AMPS. Example: 80 AMP service will be billed as per 50 AMP 3 phase \$70.00. Additional 30 AMPS x \$30.00 = \$90.00. Total \$160.00 per day for an 80 AMP electrical service.</p>
--

GENERAL CONDITIONS:
 Labor will be billed at \$50.00 per hour per engineer required for set-up and tear-down, or during the function while an engineer is required on site. Electrical work not shown above shall be charged on a time plus materials basis. All equipment must conform to all National Electric Codes. The Hilton Tucson El Conquistador reserves the right to refuse connections to any and all hazardous wiring and equipment.
 NOTE: The Hilton Tucson El Conquistador assumes no liability for failure of electrical current, supply or output, and makes no warranties that the electrical sources located at the hotel are suitable for any particular purpose.

PLEASE CHECK ONE OF THE FOLLOWING METHODS OF PAYMENT:

ROOM CHARGE ROOM NUMBER _____ REGISTERED NAME _____
 CASH CHECK CREDIT CARD: Our Event Services or Engineering Department will contact you for this information.

RETURN ORDER FORM AND CHECK MADE PAYABLE TO:
 Hilton Tucson El Conquistador Golf & Tennis Resort
 10000 N. Oracle Road
 Tucson, AZ 85704
 ATTN: Engineering Department ORDER FORMS MAY ALSO BE FAXED TO (520)544-1227



Telephone Invoice

Date:

Hotel: Contact:

Group / Event:

Group / Event Contact:

Meeting Room/Location:

Install Date:

Time:

Removal Date:

Time:

Please submit a separate form for each meeting room or area, or if you require service installed on multiple days in the same room

Types of Service Available

Line Only (for fax machines, computers, etc)	X \$50 =	X	Days=
In-house: local: long distance:			
Line & Standard Phone Set	X \$75=	X	Days =
In-house: local: long distance:			
Line & Polycom Conference Phone	X \$150 =	X	Days=
In-house: local: long distance:			
Existing House Phone	X \$25 =	X	Days =
(No charge for inhouse use, activation fee for local/long distance ability only)			
In-house: local: long distance:			
Voice Mail	X \$25 =	X	Days =
Phone line for Credit Card machine*	X \$75 =	X	Days =
* no charge for individual calls as long as only used for credit card machine			
	Activation Fee*		\$ 35.00

1FB Line

Activation Fee \$50

Daily Rental \$40.00

Explanation of Additional Charges:

Rush Fee**

Additional Charges

SubTotal

Tax @ 0%

Total Estimated Charges***

\$

\$

\$

Estimate does not include any toll charges that may be incurred.

Customer Signature of Approval _____

* Activation Fee is a one time charge for up to 12 lines per meeting room

** A 'Rush Fee' of \$75 will be charged for any requests made on-site or less than 24 hours in advance.

Local Calls: (per call) \$1.50 for the first 60 minutes, \$.10 each additional minute

Toll Free (800/888/8XX): (per call) \$2.00 for the first 60 minutes, \$.10 each additional minute

Calling Cards/Credit Cards/Collect/3rd Party Calls: (per call) \$2.00 for the first 60 minutes, \$.10 each additional minute

Directory Assistance: \$1.50 for local or long distance

Billing Instructions:

Charge to Room Account Name:

Rm# or CC#:



Hilton
Tucson El Conquistador
Golf & Tennis Resort

Internet Access Request Form

Date: _____ Hotel Contact: _____
 Group / Event: _____ Group / Event Contact: _____
 Meeting Room/Location: _____
 Install Date: _____ Meeting Start Time: _____
 Removal Date: _____ Meeting End Time: _____

Meeting Rooms:

Wireless Connections - \$25 per day per laptop

_____ Connections X _____ days

Wired Connections - \$300 per day (per jack/port)

_____ Connections X _____ days

Switch and associated cabling to break out Wired Connection(s) for up to 7 computers - \$100 per day

_____ Switches X _____ days

Guest Rooms:

Wireless Connections - \$9.95 per day per laptop

_____ Connections X _____ days

Total Charges:

Subnet Charges:

0 % Tax:

Total Charges:

Billing Instructions:

Customer Initials _____

Charge to Room Account

Charge Credit Card

Name/Room#: _____ Signature: _____ CC#: _____