

# AEX

CONVENTION SERVICES



NATIONAL ENVIRONMENTAL HEALTH ASSOCIATION  
HYATT REGENCY - ATLANTA  
JUNE 21-22, 2009

**Show Name: National Environmental Health Association**

**Show Dates: June 21-22, 2009**

**Show Location: Hyatt Regency - Atlanta**

**Deadline Date To Receive Discounted Rates: June 15, 2009**

**EXHIBITOR MOVE-IN**

<b>SUNDAY</b>	<b>JUNE 21, 2009</b>	<b>10:00 AM - 5:00 PM</b>
---------------	----------------------	---------------------------

**SHOW HOURS**

<b>SUNDAY</b>	<b>JUNE 21, 2009</b>	<b>6:00 PM - 9:00 PM</b>
---------------	----------------------	--------------------------

<b>MONDAY</b>	<b>JUNE 22, 2009</b>	<b>8:00 AM - 3:00 PM</b>
---------------	----------------------	--------------------------

**EXHIBITOR MOVE-OUT**

<b>MONDAY</b>	<b>JUNE 22, 2009</b>	<b>3:00 PM - 6:00 PM</b>
---------------	----------------------	--------------------------

Move-Out Note: All carriers must check in no later than on Monday, June 22, 2009 by 4:00 PM or freight will be shipped C.O.D. via LibertyCFS.

**SHOW COLORS:**

Back Drape: TEAL & WHITE

Side Drape: TEAL

Carpet: HOTEL MULTI-COLORED

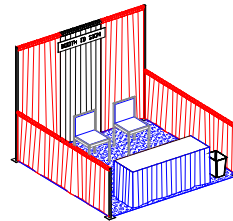

**BOOTH EQUIPMENT:**

Each booth will be provided with an 8' TEAL & WHITE background drape, 36" TEAL side divider drapes, 6' draped table, waste-basket and booth ID sign.

**CARPET COLOR:**

The booth area and aisles are carpeted in HOTEL MULTI-COLOR.

**ADVANCE WAREHOUSE:**

AEX Convention Services

National Environmental Health Association

Exhibiting Company Name / Booth Number

c/o RAC Logistics

99 University Ave., Atlanta, GA 30315

Materials should be shipped to ARRIVE at our warehouse **NO LATER THAN JUNE 8, 2009**. Any shipments received more than 30-days prior to the Move-In will incur additional charges.

**DIRECTLY TO FACILITY:**

Hyatt Regency - Atlanta

National Environmental Health Association

Exhibiting Company Name / Booth Number

c/o AEX Convention Services

265 Peachtree Street NE, Atlanta, GA 30303

Shipments will be received at the exhibit facility on: **JUNE 21, 2009** between 10:00 AM - 5:00 PM

**ASSISTANCE:**

If you have any questions or would like assistance, please call our office at (609) 272-1600.





**Show Name: National Environmental Health Association**

**Show Dates: June 21-22, 2009**

**Deadline Date To Receive Discounted Rates: June 15, 2009**

**AEX CONVENTION SERVICES**

Administrative Offices  
3089 English Creek Ave.  
Egg Harbor Twp., NJ 08234  
Phone: (609) 272-1600  
Fax: (609) 272-1680

**ADVANCE WAREHOUSE**

LibertyCFS  
c/o RAC Logistics  
99 University Ave.  
Atlanta, GA 30315

**AIR, GROUND & VAN LINE  
FREIGHT SERVICES**

LibertyCFS, Inc.  
Phone: (905) 338-3993  
Fax: (905) 338-1092

**AUDIO/VISUAL RENTAL  
SERVICES P.S.A.V.**

Swank Audio Visual  
Hyatt Regency - Atlanta  
265 Peachtree NE  
Atlanta, GA 30303  
Phone: (404) 460-6550  
Fax: (404) 460-6464

**SHOW MANAGEMENT**

National Environmental Health Association  
720 So. Colorado, Blvd., Suite 1000-N  
Denver, CO 80246  
Phone: (303) 756-9090 Ext. 342

**FLORAL SERVICE**

AEX Convention Services  
Phone: (609) 272-1600  
Fax: (609) 272-1680

**SPECIALTY FURNITURE SERVICE**

AEX Convention Services  
Phone: (609) 272-1600  
Fax: (609) 272-1680

**TELEPHONE SERVICE**

Hyatt Regency - Atlanta  
Phone: (404) 577-1234  
Fax: (404) 588-4137

**ELECTRICAL SERVICE**

Hyatt Regency - Atlanta  
265 Peachtree Street NE  
Atlanta, GA 30303  
Phone: (404) 577-1234  
Fax: (404) 588-4137



Please mail or fax forms to AEX Convention Services.





**LIMITS & LIABILITIES AND TERMS AND CONDITIONS  
BY USING OUR SERVICES OR SIGNING THE AGREEMENT TO TERMS AND CONDITIONS, YOU AND YOUR  
COMPANY AGREE TO THE FOLLOWING**

DRAYAGE/FREIGHT RATES APPLY to each pound with a minimum (see front for actual minimum) and are based on the actual or estimated INBOUND weight. No allowance will be made for during the event. Each shipment is considered separately. NO cumulative weights will be allowed on minimums, split shipments, etc.

SHIPMENTS OF EQUIPMENT REQUIRING SPECIAL HANDLING at the facilities will be subject to a surcharge as indicated on the freight rate schedule. This classification shall be applied to, but not limited to, van shipments or shipments which are packed in such a manner as to require unloading by hand (e.g., loose display parts, uncrated equipment, etc.) Material will be unloaded from vans, exhibitor's truck, or trucks of others at the facility, delivered to the Exhibitor's booth, picked up at the close of the show, moved to the loading area and reloaded. The Exhibitor must provide written and accurate weight information on each shipment. Shipments received without Certified Weight Tickets or Bills of Lading, such as UPS or U.S. Mail, will be delivered to the booth without guarantee of piece count or condition. No liability will be assumed for such shipments.

SPECIAL SERVICES AND RATES - Steel banding for the packing of displays and equipment is available at the AEX Convention Services service desk for \$2.00 per linear ft. plus labor at prevailing rates. Forklifts and drivers are available for spotting equipment in the booth at prevailing rates for equipment and labor. Shrink-Wrap is available at a flat rate of \$45.00 per 4'x4'x4' pallet, thereafter pro-rata.

EMPTY CONTAINER STORAGE - Properly labeled empty containers of freight handled by AEX Convention Services will be removed and returned to the booth; "empty" labels will be available at the service desk. Affixing labels is the sole responsibility of the Exhibitor or representative who must remove or obliterate all old labels. AEX Convention Services assumes no responsibility for removal of containers with old empty storage labels or without AEX Convention Services labels, improper information on empty labels or valuables stored in containers with empty labels. Handling of empty containers of freight not brought in by AEX Convention Services will be charged \$15.00 per box or crate each way.

OUTBOUND SHIPPING INSTRUCTIONS should be given to AEX Convention Services during the event or immediately after its close. All bills of lading and shipping instructions covering outbound shipments will be checked at the time of actual loading and corrections made where discrepancies exist. Freight remaining on the exhibit floor without proper instructions for disposition will be removed by AEX Convention Services and shipped with the information available at the time using a carrier of AEX Convention Service's choice or brought to AEX's warehouse storage and handling will be charged. AEX Convention Services will not be liable for shipping errors subsequent to the event unless it has agreed to specific written instructions has failed to honor them. The condition, count, and contents of the materials found in the booth at the time of actual removal will be final and binding and the right is reserved to alter exhibitor's bill of lading to reflect actual condition, count, and content found.

LIMITATIONS OF LIABILITY - AEX Convention Services IS NOT responsible for damage to materials improperly packed, concealed damage, loss or theft of Exhibitors' material after same has been delivered to your booth, or before materials have been picked up for loading out of the booth. AEX Convention Services makes no warranties or claims except as may be set forth in these terms and conditions. No oral modifications may be made to these terms. Regardless of your claim, AEX Convention Service's liability with respect to your freight or any damage whatsoever, is limited to \$.10 per pound/per article, with a maximum of \$50.00 per item, and a maximum of \$1,000.00 per shipment, even in the event of AEX Convention Service's negligence. AEX's liability for any damages whatsoever when you hire us for supervised installation/dismantle is limited to the actual cost for supervision.

EXHIBIT LOSS OR DISAPPEARANCE - AEX Convention Services and its subcontractors ARE NOT responsible for loss or disappearance of Exhibitor's material after such material has been delivered to the Exhibitor's booth. Relative to inbound shipments, there may be a lapse of time between the delivery of shipment(s) to the applicable booth by AEX Convention Services or its subcontractors, and the arrival of Exhibitor's representative at the booth. During such time the shipment(s) will be left unattended in the booth. AEX Convention Services or its subcontractors shall not be responsible for any loss or damage that may occur during such a period.

Similarly, AEX Convention Services and its subcontractors ARE NOT responsible for loss or disappearance of Exhibitor's material before Exhibitor's material is picked up from the Exhibitor's booth for loading after the exhibition. All bills-of-lading covering outgoing shipment that are given to AEX Convention Services by the Exhibitor will be checked at the time of pick-up from the booth, and corrections will be made at such time if discrepancies exist. Relative to outgoing shipments, it is possible that there will be a lapse of time between the completion of the packing and the pick up material from the booths for loading onto a damage that may occur during such period. AEX Convention Services and its subcontractors are not responsible for any loss or damage that may occur during such period. AEX Convention Services and its subcontractors will adjust the quantities of items on any bill-of-lading submitted to AEX Convention Services or its subcontractors to conform to the actual count of such items in the booth at the time of pick-up and shipment.

DISPUTES - In the event of any dispute between an Exhibitor and AEX Convention Services relative to any loss or damage to such Exhibitor's material, such Exhibitor shall not be entitled to and shall not withhold payment of any amount due to AEX Convention Services for services or rentals provided as any offset against the amount of any alleged loss or damage. Instead, such Exhibitor shall pay AEX Convention Services for any rental or services and Exhibitor may pursue any claim against AEX Convention Services independently. No claims for loss or damage will be considered until payment in full for all services performed by AEX Convention Services has been received.

INSURANCE - Exhibitors agree to carry all-risk floater insurance covering their material against damage, loss, theft and all hazards which covers from the time shipment is made prior to show until shipments are returned to Exhibitor after the show.

We require full payment with order for rentals, service, tax and anticipated freight. This Form, with your credit card information for payment of advance and show site orders, must be completed, mailed or faxed to AEX Convention Services in order for us to provide any rentals or services. Full payment must accompany your order to qualify for the discounted rates. A \$25.00 surcharge will be added to your account if any credit charges are denied or if any checks are returned. Unpaid account will accrue a service charge of 1.5% per month. Exhibitor agrees to be responsible for all fees connected with the collection of its accounts.



# FURNITURE RENTAL ORDER FORM

Please Mail or Fax Completed Form to: AEX Convention Services  
 3089 English Creek Ave., Egg Harbor Township, NJ 08234  
 Fax: (609) 272-1680 • Phone: (609) 272-1600

**Show Name: National Environmental Health Association**

**Show Dates: June 21-22, 2009**

**Deadline Date To Receive Discounted Rates: June 15, 2009**

## FURNITURE

Description	Discount	Standard	Qty.	Total
Plastic Side Chair	\$38.75	\$54.25	_____	_____
Padded Arm Chair	\$55.25	\$77.25	_____	_____
Padded Counter Stool	\$60.25	\$84.50	_____	_____
Cocktail Table 18''H	\$67.75	\$94.75	_____	_____
Cocktail Table 30''H	\$83.00	\$116.00	_____	_____
Cocktail Table 42''H	\$97.75	\$136.75	_____	_____
Literature Rack	\$164.75	\$231.00	_____	_____
Security Cage	\$262.50	\$367.50	_____	_____
Wastebasket	\$16.25	\$22.75	_____	_____
Easel	\$40.50	\$56.75	_____	_____
Chrome Sign Frame (22'' x 28'')	\$47.25	\$66.25	_____	_____
Waterfall Clothing Rack	\$42.00	\$58.75	_____	_____
Chrome Stanchion	\$44.00	\$61.75	_____	_____
Chrome Bag Holder	\$44.00	\$61.75	_____	_____
Chrome Clothes Tree	\$44.00	\$61.75	_____	_____
White/Silver Plastic Chain(/ft.)	\$6.75	\$9.50	_____	_____
Crossbar	\$19.00	\$26.50	_____	_____
Upright with Base	\$23.50	\$33.00	_____	_____

## DISPLAY TABLES (Price includes top covered with white plastic and 3 sides draped)

Description	Discount	Standard	Qty.	Total
4' L x 24'' W x 30'' H	\$90.75	\$127.00	_____	_____
4' L x 24'' W x 42'' H	\$121.75	\$170.50	_____	_____
6' L x 24'' W x 30'' H	\$109.75	\$153.50	_____	_____
6' L x 24'' W x 42'' H	\$141.75	\$198.50	_____	_____
8' L x 24'' W x 30'' H	\$127.00	\$178.00	_____	_____
8' L x 24'' W x 42'' H	\$158.50	\$222.00	_____	_____
4th Side Drape 30''	\$41.00	\$57.50	_____	_____
4th Side Drape 42''	\$46.75	\$65.50	_____	_____

- Please select color:**
- Burgundy
  - Blue
  - Teal
  - Black
  - Purple
  - Gray
  - Gold
  - Green
  - White
  - Red

Undraped Tables are 25% off of draped rate. (Circle size above)

## TABLETOP RISERS -12''w x 8''h (Covered in white plastic)

Description	Discount	Standard.	Qty.	Total
4' Long, Single Step	\$43.00	\$60.25	_____	_____
6' Long, Single Step	\$55.25	\$77.25	_____	_____

- Please select color:**  
 (For background & side rail drape only)
- Burgundy
  - Blue
  - Teal
  - Black
  - Purple
  - Gray
  - Gold
  - Green
  - White
  - Red

Uncovered Risers are 25% off of the covered rate. (Circle size above)

## DRAPES (Drape rates are per linear foot)

Description	Discount	Standard	Qty.	Total
8' Background Drape / lin. ft.	\$16.25	\$22.75	_____	_____
Side Rail Drape 42''h. / lin. ft.	\$12.50	\$17.50	_____	_____

FURNITURE ORDER TOTAL: \$ \_\_\_\_\_

Company Name: \_\_\_\_\_ Booth#: \_\_\_\_\_

YES, I have completed and enclosed the Authorization and Agreement to Terms and Conditions Form and I understand that all orders are subject to Georgia State Sales tax 8%.

Show Name: National Environmental Health Association

Show Dates: June 21-22, 2009

Deadline Date To Receive Discounted Rates: June 15, 2009

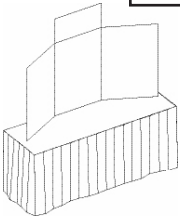
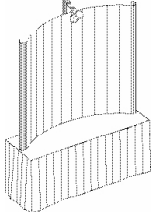
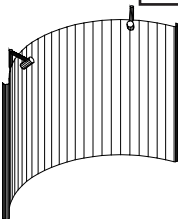
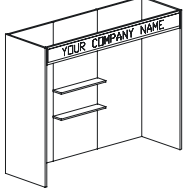
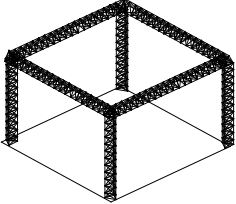
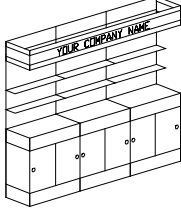
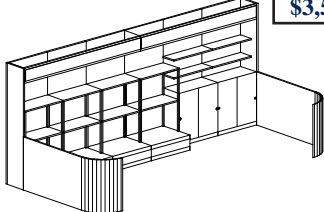
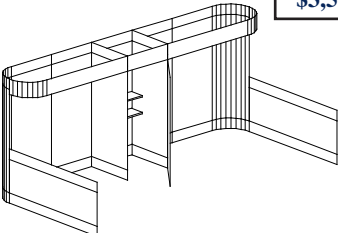
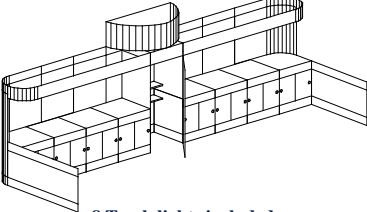
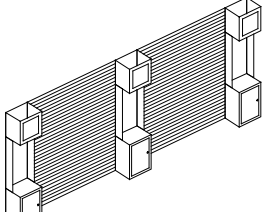
<p>(#1) Panel Tabletop \$325.50</p>  <p>60" wide x 36" high tabletop unit in silver. Velcro compatible</p>	<p>(#2) Curved Tabletop Pop-up \$519.75</p>  <p>68" wide x 64" high tabletop unit in silver. Velcro compatible with 1 spotlight</p>	<p>(#3) Pop-up Display \$987.00</p>  <p>10' wide x 7' compatible with 2 spotlights</p>	<p>(#4) 10' x 10' Hard wall Unit \$1,758.75</p>  <p>3 Track lights included</p>
<p>(#5) 20' x 20' Truss Unit \$4,620.00</p>  <p>Truss Exhibit available in various sizes</p>	<p>(#6) 10' x 10' Counter Exhibit \$1,869.00</p>  <p>3 Track lights included</p>	<p>(#7) 10' x 20' Shelf Unit \$3,522.75</p>  <p>6 Track lights included</p>	
<p>(#8) 10' x 20' Curved Exhibit \$3,522.75</p>  <p>6 Track lights included</p>	<p>(#9) 10' x 30' Curved Exhibit \$4,961.25</p>  <p>8 Track lights included</p>	<p>(#10) 10' x 20' Professional Exhibit \$4,620.00</p>  <p>3 Lights boxes, 3 Locking counters, Slatwall. Professionally Black Laminated</p>	

**NOTE:** Above prices include delivery, installation and removal. Please see our Furniture and Carpet Rental Order Forms if you would like to order carpet or furniture.

- ❖ Additional Lights Qty. \_\_\_\_\_ Light @\$66.25 each = \$ \_\_\_\_\_
- ❖ Additional Hardware Shelves Qty. \_\_\_\_\_ Shelves @\$45.00 each = \$ \_\_\_\_\_
- ❖ Aluminum Slatwall Per Panel Qty. \_\_\_\_\_ Slatwall @\$125.00 each = \$ \_\_\_\_\_
- ❖ Units 4, 6, 7, 8, & 9 are provided in white hard wall unless colored or Velcro compatible panels are ordered.
  - Red   ○ Blue   ○ Black   ○ Gray
  - Qty. \_\_\_\_\_ Colored panels @\$11.00 each = \$ \_\_\_\_\_
  - Qty. \_\_\_\_\_ Velcro panels @\$27.75 each = \$ \_\_\_\_\_
- ❖ Matching counters 42" H x 21" L x 40" W Qty. \_\_\_\_\_ Counters @\$275.00 each = \$ \_\_\_\_\_

❖ Please call to discuss your sign requirements and pricing. Standard signage is black letters on a white background.

**PRINT SIGN TEXT ON A SEPARATE SHEET:**

- ❖ If you require a Custom Exhibit Design not shown above, please call (609) 272-1600
- ❖ Electric service IS NOT included. Please make arrangements in advance with exhibit facility.

Company Name: \_\_\_\_\_ Booth#: \_\_\_\_\_  
 Unit# \_\_\_\_\_ Unit Price \$ \_\_\_\_\_

Add 30% if ordered after deadline \$ \_\_\_\_\_

**SUBTOTAL, MODULAR EXHIBIT RENTAL ORDER \$ \_\_\_\_\_**

YES, I have completed and enclosed the Authorization and Agreement to Terms and Conditions Form and I understand that all orders are subject to Georgia State Sales tax 8%.



# CARPET RENTAL ORDER FORM

Please Mail or Fax Completed Form to: AEX Convention Services  
 3089 English Creek Ave., Egg Harbor Township, NJ 08234  
 Fax: (609) 272-1680 • Phone: (609) 272-1600  
 www.aexservices.com

**Show Name: National Environmental Health Association**

**Show Dates: June 21-22, 2009**

**Deadline Date To Receive Discounted Rates: June 15, 2009**

**STANDARD BOOTH CARPET** (Standard booth carpet is not available for Island Booths. Please see the Cut & Lay carpet below.)

Description	Discount	Standard	Total	Please select color:		
9' x 10'	\$122.75	\$171.75	\$ _____	<input type="radio"/> Black	<input type="radio"/> Gray	<input type="radio"/> Burgundy
9' x 20'	\$245.50	\$343.75	\$ _____	<input type="radio"/> Teal	<input type="radio"/> Purple	<input type="radio"/> Green
9' x 30'	\$368.25	\$515.50	\$ _____	<input type="radio"/> Blue	<input type="radio"/> Red	<input type="radio"/> Lime Green
9' x 40'	\$491.00	\$687.50	\$ _____			

**Over 9' x 40' available pro rata.**

This carpet is not designed to cover complete booth areas since the rental cost does not include seaming and the carpets are not guaranteed to be a color match. If complete exhibit area carpet is desired, see cut & lay section below.

- Add padding with the purchase of Rental Carpet for \$52.50 per 10' x 10' booth space.
- Add protective plastic covering with the purchase of Rental Carpet for \$42.00 per 10' x 10' booth space.

Number of 10' x 10' Booth Space(s) \_\_\_\_\_ x \$52.50 = \_\_\_\_\_  
 Number of 10' x 10' Booth Space(s) \_\_\_\_\_ x \$42.00 = \_\_\_\_\_

**CUT & LAY CARPET** (100 sq. ft. Minimum Order)

Complete Area Size: \_\_\_\_\_ Ft. x \_\_\_\_\_ Ft. = \_\_\_\_\_ Sq. Ft. @

Discount	Standard	Total
\$3.00/sq.ft.	\$4.00/sq.ft. =	\$ _____

- Please select color:**
- Black
  - Gray
  - Burgundy
  - Teal
  - Purple
  - Green
  - Blue
  - Red
  - Lime Green

**DECORATIONS PLUSH CARPET** (Subject to availability)

Complete Area Size: \_\_\_\_\_ Ft. x \_\_\_\_\_ Ft. = \_\_\_\_\_ Sq. Ft. @

Description	Discount	Standard	Total
34 oz.	\$4.50/sq.ft.	\$6.50/sq.ft. =	\$ _____
50 oz.	\$6.00/sq.ft.	\$8.75/sq.ft. =	\$ _____

- Please select color:**
- Dusty Rose
  - Light Teal
  - Toast
  - Ivory
  - Cream
  - Sandstone
  - Baby Blue
  - Sky Blue
  - Navy
  - Misty Gray
  - Silver Mist
  - Gun Metal
  - Cherry Red
  - Burgundy
  - Forest Green
  - Ebony

Order must be received at least four weeks prior to the show.  
 Custom carpet is a luxurious 34 oz. Or 50 oz. Carpet available in assorted decorator colors.  
 Swatches will be sent to you upon your request. Minimum order for decorators plush carpet is 200 sq. ft.

(All prices include installation and removal) **SUBTOTAL CARPET RENTAL ORDER: \$ \_\_\_\_\_**

**YES, I have completed and enclosed the Authorization and Agreement to Terms and Conditions Form and I understand that all orders are subject to Georgia State Sales tax 8%.**

**Company Name:** \_\_\_\_\_ **Booth#:** \_\_\_\_\_

# PERFBOARD/TACKBOARD RENTAL ORDER FORM

Please Mail or Fax Completed Form to: AEX Convention Services  
 3089 English Creek Ave., Egg Harbor Township, NJ 08234  
 Fax: (609) 272-1680 • Phone: (609) 272-1600

**Show Name: National Environmental Health Association**

**Show Dates: June 21-22, 2009**

**Deadline Date To Receive Discounted Rates: June 15, 2009**

### GRID WALL

Each Panel is 2' x 8' with a 3" x 3" grid.

At least two panels are needed to be free standing without the use of feet.

Feet must be rented to have individual (2' x 8') free standing units.

Feet are supplied attached to each free standing unit.

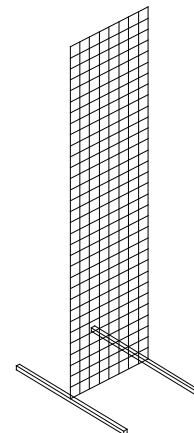
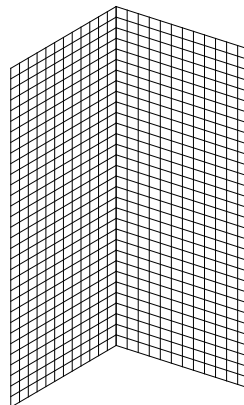

Description	Discount	Standard		Total
_____ 2' x 8'	\$72.25	\$101.00	each =	\$ _____
_____ Pair of feet	\$29.00	\$40.50	each =	\$ _____

### WHITE PERF BOARD (Shown Below)

### WHITE TACK BOARD

Description	Discount	Standard	Qty.	Total
Style A - 2' w x 8' h Panel	\$93.50	\$130.75	_____	\$ _____
Style A - 4' w x 8' h Panel	\$136.50	\$191.00	_____	\$ _____
Style B - 8' w x 2' h Panel	\$93.50	\$130.75	_____	\$ _____
Style B - 8' w x 4' h Panel	\$136.50	\$191.00	_____	\$ _____
Style C - 10' w x 8' h Panel	\$565.00	\$791.00	_____	\$ _____
Perf Board Shelving 4' long	\$28.75	\$40.50	_____	\$ _____

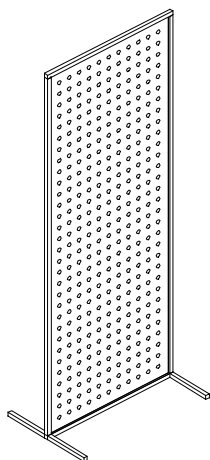

Style A  
Vertical to Floor

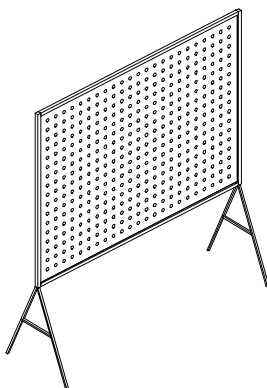

Style B  
Horizontal off Floor  
(30" Off the Floor)

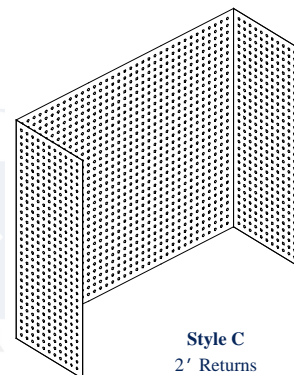

Style C  
2' Returns

SUBTOTAL GRID WALL, PERF BOARD & TACK BOARD ORDER: \$ \_\_\_\_\_

YES, I have completed and enclosed the Authorization and Agreement to Terms and Conditions Form and I understand that all orders are subject to Georgia State Sales tax 8%.

Company Name: \_\_\_\_\_ Booth#: \_\_\_\_\_



# SHOWCASE RENTAL ORDER FORM

Please Mail or Fax Completed Form to: AEX Convention Services  
 3089 English Creek Ave., Egg Harbor Township, NJ 08234  
 Fax: (609) 272-1680 • Phone: (609) 272-1600

**Show Name: National Environmental Health Association**

**Show Dates: June 21-22, 2009**

**Deadline Date To Receive Discounted Rates: June 15, 2009**

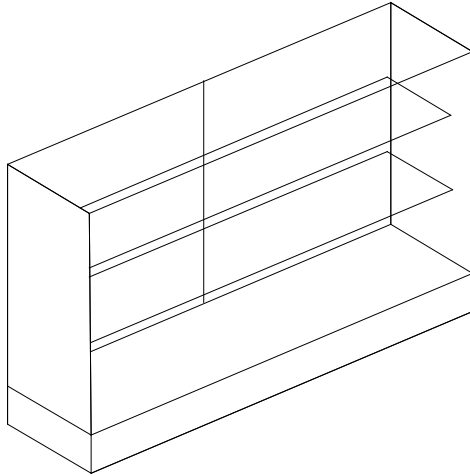

**EXTRA VISION SHOWCASE**  
(Thin Aluminum Frame)

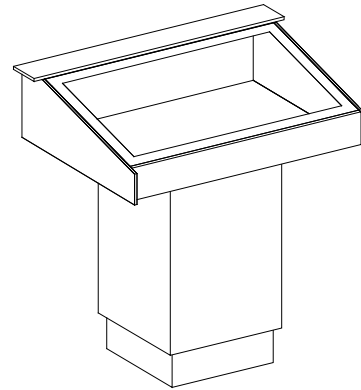

**TOP VISION SHOW CASE**

Glass shelves are used in these items. To prevent breakage of shelves and articles, good judgement must be used during installation and loading of glass shelves. Take care in placing heavy items or large quantities of items on these glass shelves. A sudden shock, even from small items dropped, can result in broken glass causing personal injury as well as loss of treasured valuables. AEX Convention Services does not assume responsibility for broken glass and/or personal valuables. Rental price includes delivery to and removal from your booth space.

**PLEASE MAKE YOUR SELECTION BELOW**

Type	Qty.	Discount	Standard	Total
Extra Vision Showcase 38" H x 20" D x 70"	_____	\$413.75	\$579.00	_____
Top Vision Showcase 49" H x 39" D x 43"	_____	\$367.50	\$514.50	_____
Additional Shelves	_____	\$26.75	\$37.50	_____
Locks	_____	\$24.75	\$34.75	_____

Electrical Orders must be placed with the **ELECTRICAL SERVICE FORM**

ALL ORDERS ARE SUBJECT TO AVAILABILITY.

ADDITIONAL CASES AVAILABLE UPON REQUEST, PLEASE CALL.



SUBTOTAL SHOWCASE RENTAL ORDER: \$ \_\_\_\_\_

YES, I have completed and enclosed the Authorization and Agreement to Terms and Conditions Form and I understand that all orders are subject to Georgia State Sales tax 8%.

Company Name: \_\_\_\_\_ Booth#: \_\_\_\_\_



# MATERIAL HANDLING ORDER FORM

Please Mail or Fax Completed Form to: AEX Convention Services  
 3089 English Creek Ave., Egg Harbor Township, NJ 08234  
 Fax: (609) 272-1680 • Phone: (609) 272-1600

**Show Name: National Environmental Health Association**

**Show Dates: June 21-22, 2009**

**MATERIAL HANDLING RATES - ROUND-TRIP RATES, PER SHIPMENT, USE INCOMING WEIGHT ONLY AND ROUND UP TO THE NEXT 100 LBS. THESE RATES ARE SUBJECT TO SURCHARGE (See Below).**

**SHIPMENTS RECEIVED WITHOUT BILLS OF LADING, SUCH AS UPS OR FED EX WILL BE DELIVERED TO THE BOOTH WITHOUT GUARANTEE OF PIECE COUNT OR CONDITION.**

**CERTIFIED WEIGHT TICKETS ARE REQUIRED FOR EACH SHIPMENT, IF NOT PROVIDED, YOU AGREE TO USE AEX CONVENTION SERVICES' ESTIMATED WEIGHTS.**

**RATE PER 100 LBS. (200 L.B. MIN.)**

(CWT - 100 lbs.)

Description	Receiving	S.T. In / S.T. Out	Overtime In or Out	O.T. In / O.T. Out
<b>A1</b> - ON TIME Crated or Skidded shipments (LTL Carriers with established local terminals)	Advance Warehouse	\$63.00 per cwt. \$126.00 minimum	\$94.50 per cwt. \$189.00 minimum	\$141.75 per cwt. \$283.50 minimum
<b>A2</b> - VAN LINES (Irregular route carrier)	Advance Warehouse	\$94.50 per cwt. \$189.00 minimum	\$141.75 per cwt. \$283.50 minimum	\$212.75 per cwt. \$425.50 minimum
<b>B1</b> - ON TIME Crated or Skidded shipments (LTL Carriers with established local terminals)	Convention Site	\$63.00 per cwt. \$126.00 minimum	\$94.50 per cwt. \$189.00 minimum	\$141.75 per cwt. \$283.50 minimum
<b>B2</b> - VAN LINES and loose and uncrated shipments (Irregular route carrier)	Convention Site	\$94.50 per cwt. \$189.00 minimum	\$141.75 per cwt. \$283.50 minimum	\$212.75 per cwt. \$425.50 minimum

**(S.T. = Straight Time / O.T. =Overtime)**

A transfer fee of \$125.00 + \$12.00 per cwt. will apply for all shipments going to AEX Convention Service's Warehouse to be pick-up by outside carriers. This fee of \$125.00 will apply for all shipments returning to AEX Convention Services Warehouse after the conference is over to be picked up by outside carriers or shipped to other events.

Overtime Rates will apply if:

- Inbound vehicles arrive at the dock weekdays prior to 8:00 AM or after 3:00 PM or anytime Saturday, Sunday and Holidays
- Outbound vehicles are loaded weekdays prior to 8:00 AM or after 3:00 PM or anytime Saturday, Sunday and Holidays.
- Warehouse freight is moved to the event floor on overtime due to scheduling.

A 50% surcharge will apply if: freight is received after the "last day accepted" for Advance warehouse shipments or outside indicated times to the convention site.

Estimated charges for material handling..... lbs. x \_\_\_\_\_ per cwt. = \$ \_\_\_\_\_  
Estimated Weight Estimated Rate Total Estimated Material Handling

**SUBTOTAL MATERIAL HANDLING ORDER: \$ \_\_\_\_\_**

**YES, I have completed and enclosed the Authorization and Agreement to Terms and Conditions Form and I understand that all orders are subject to Atlanta, GA State Sales tax 8%**



ADVANCE WAREHOUSE SHIPPING

Show Name: National Environmental Health Association

Show Dates: June 21-22, 2009

**ADVANCE WAREHOUSE SHIPPING**

**TRADE SHOW SHIPMENT - PLEASE EXPEDITE**

To: \_\_\_\_\_  
Name of Exhibitor

Booth: \_\_\_\_\_

**NATIONAL ENVIRONMENTAL HEALTH ASSOCIATION  
C/O RAC LOGISTICS  
99 UNIVERSITY AVENUE  
ATLANTA, GA 30315**

Deliver NO LATER than JUNE 8, 2009



Receiving 8am-3pm, Monday-Friday  
Check In by 2pm



DIRECT SHIPMENT

Show Name: National Environmental Health Association

Show Dates: June 21-22, 2009

**DIRECT SHIPMENT TO THE HYATT REGENCY -  
ATLANTA**

To: \_\_\_\_\_  
Name of Exhibitor

Booth: \_\_\_\_\_

**HYATT REGENCY - ATLANTA  
NATIONAL ENVIRONMENTAL HEALTH ASSOCIATION  
C/O AEX CONVENTION SERVICES  
265 PEACHTREE STREET NE  
ATLANTA, GA 30303**



Deliver ON JUNE 21, 2009 Between 10:00 AM - 5:00 PM



# LABOR SERVICE FORM

Please Mail or Fax Completed Form to: AEX Convention Services  
 3089 English Creek Ave., Egg Harbor Township, NJ 08234  
 Fax: (609) 272-1680 • Phone: (609) 272-1600

**Show Name: National Environmental Health Association**

**Show Dates: June 21-22, 2009**

**Deadline Date To Receive Discounted Rates: June 15, 2009**

**PLAN A: PROFESSIONALLY SUPERVISED INSTALLATION AND DISMANTLING** (see next page for important shipping information)

### LET US DO THE WORK FOR YOU - YOU WALK AWAY!

- Supervision by our professionals
- Installation and dismantling by experienced laborers
- Materials prepared for shipment to next destination
- Empties stored during event
- Shipping labels provided

Please forward detailed instructions, blueprints or photos and complete the information on the back of this form. Our cost for this service is 35% of your total labor bill (\$35.00 minimum). This service provides our expert supervision and saves the expense and productive time of your own personnel. Please note: Our liability for damages, for whatever reason, is limited to our billed cost for supervision.

**PLAN B: EXHIBITOR'S SUPERVISION**

- Installation and dismantling by experienced laborers
- Empties stored during event

For those using Plan B, on the day and time that you have requested labor, please report to the AEX Convention Services Desk to pick-up and sign out your labor crew. You will be charged a one hour minimum per laborer ordered if you do not report to the Service Desk at the time you have requested labor. The labor crew will not be sent to your booth without being signed out. Upon completion of their work, you are required to accompany the laborers back to the AEX Convention Services Desk and sign them in. All exhibitors ordering labor will be billed a one-hour minimum for each person ordered unless a written cancellation order is received by 11:00 am the day before the labor is supplied. It is not necessary to order labor for unloading freight (see Material Handling Order Form). ALL WORK IS DONE ONLY UNDER THE SUPERVISION OF THE EXHIBITOR'S REPRESENTATIVE.

**LABOR RATES: 1 HOUR MINIMUM PER PERSON, 1 HOUR INCREMENTS THEREAFTER**  
**PLEASE NOTE: LIGHTS, ELECTRIC MOTORS AND OTHER ELECTRICAL COMPONENTS REQUIRE THE USE OF ELECTRICIAN LABOR. IF NECESSARY, YOU WILL BE CHARGED ACCORDINGLY.**

	Discount	Standard
<u>Straight Time</u> (Monday through Friday between 8 am - 4:30 pm)	\$77.25 per hour	\$108.25 per hour
<u>Overtime</u> (Monday through Friday before 8 am and after 4:30 pm and anytime Saturday or Sunday)	\$115.75 per hour	\$162.00 per hour
<u>Double Time</u> (Anytime on Holidays)	\$154.50 per hour	\$216.25 per hour

Starting time can be guaranteed only in those instances where workers are requested for the start of published move-in times (usually 8:00 am). Please indicate service desired by checking either Plan A or Plan B. If no plan is indicated, labor cannot be assigned until exhibitor's representative reports to the service desk.

	Estimated Hours	Start Date	Start Time	Estimated Finished Time	# of Laborers	Rate	AEX Supervision	Estimated Total Cost
Installation								
Dismantle								

Dismantle - you will be charged for the same estimated hours and number of laborers for dismantle. In the event less chargeable time is used, we will credit you following the close of the show. All labor provided at show site but not ordered in advance will be charged at the standard rate.

SUBTOTAL ESTIMATED LABOR SERVICE ORDER: \$ \_\_\_\_\_

**YES, I have completed and enclosed the Authorization and Agreement to Terms and Conditions Form and I understand that all orders are subject to Georgia State Sales tax 8%.**

**Company Name:** \_\_\_\_\_ **Booth#:** \_\_\_\_\_



# SUPERVISED INSTALLATION AND DISMANTLE INFORMATION SHEET

Please Mail or Fax Completed Form to: AEX Convention Services  
3089 English Creek Ave., Egg Harbor Township, NJ 08234  
Fax: (609) 272-1680 • Phone: (609) 272-1600

**Show Name: National Environmental Health Association**

**Show Dates: June 21-22, 2009**

**Deadline Date To Receive Discounted Rates: June 15, 2009**

Print Your Company Name: \_\_\_\_\_

Booth# \_\_\_\_\_

## COMPLETE THIS FORM ONLY IF YOU HAVE SELECTED

### Plan A: Professionally Supervised Installation and Dismantle

*This information is required in order to ensure proper supervision and installation of your display.*

Freight is arriving at  Warehouse  Show Site Loading Dock

Date Shipped: \_\_\_\_\_ Via: \_\_\_\_\_ (freight carrier)

Display shipped from: \_\_\_\_\_ (address)

# of Crates: \_\_\_\_\_ # of Cartons: \_\_\_\_\_ Estimated Weight: \_\_\_\_\_

Display Includes: \_\_\_\_\_

Booth carpet in shipment?  Yes  No

Set-up instructions:  Attached to this order  With display

### RETURN SHIPPING:

Return Display to the following address:

\_\_\_\_\_  
\_\_\_\_\_  
\_\_\_\_\_  
\_\_\_\_\_

Via: \_\_\_\_\_ (carrier)

### EMERGENCY CONTACT AT SHOW SITE:

Name: \_\_\_\_\_ Arrival Date: \_\_\_\_\_

Hotel: \_\_\_\_\_ Telephone: \_\_\_\_\_

YES, I have completed and enclosed the Authorization and Agreement to Terms and Conditions Form and I understand that all orders are subject to Georgia State Sales tax 8%.

Company Name: \_\_\_\_\_ Booth#: \_\_\_\_\_



# EAC/Third Party Billing

Please Mail or Fax Completed Form to: AEX Convention Services  
 3089 English Creek Ave., Egg Harbor Township, NJ 08234  
 Fax: (609) 272-1680 • Phone: (609) 272-1600

**Show Name: National Environmental Health Association**

**Show Dates: June 21-22, 2009**

**Deadline Date To Receive Discounted Rates: June 15, 2009**

**To: AEX Services**

Please be advised that we will be using an independent contractor of our own choosing to perform installation/dismantle labor services at the Hyatt Regency - Atlanta. We are aware that a responsible representative of our contractor must report to the AEX Service Desk on the first day of set-up. No badges will be issued until all pertinent paperwork is in order.

Third Party/Display House:

Address: \_\_\_\_\_  
 City : \_\_\_\_\_ State: \_\_\_\_\_ Zip: \_\_\_\_\_  
 Contact: \_\_\_\_\_  
 Phone Number: \_\_\_\_\_ Booth Number: \_\_\_\_\_  
 Your Name: \_\_\_\_\_ Your Signature: \_\_\_\_\_  
 Date: \_\_\_\_\_

## Display house must also provide a Certificate of Insurance to AEX

	Exhibitor will pay	Third Party will pay	
Furniture	<input type="radio"/>	<input type="radio"/>	\$ _____
Carpet	<input type="radio"/>	<input type="radio"/>	\$ _____
Labor	<input type="radio"/>	<input type="radio"/>	\$ _____
Cleaning	<input type="radio"/>	<input type="radio"/>	\$ _____
Freight	<input type="radio"/>	<input type="radio"/>	\$ _____
Utilities	<input type="radio"/>	<input type="radio"/>	\$ _____
Other Services	<input type="radio"/>	<input type="radio"/>	\$ _____



**Acceptance of this third party billing is contingent upon:**

An Authorization Form, the Insurance Form and return of the notification letter prior to the deadline date.

**Company Name:** \_\_\_\_\_ **Booth#:** \_\_\_\_\_



# CLEANING SERVICE ORDER FORM

Please Mail or Fax Completed Form to: AEX Convention Services  
 3089 English Creek Ave., Egg Harbor Township, NJ 08234  
 Fax: (609) 272-1680 • Phone: (609) 272-1600

**Show Name: National Environmental Health Association**

**Show Dates: June 21-22, 2009**

**Deadline Date To Receive Discounted Rates: June 15, 2009**

**USE THIS FORM TO ORDER CLEANING SERVICE WITHIN YOUR BOOTH SPACE AND FOR DEBRIS ACCUMULATED DURING SET-UP AND EXHIBIT HOURS.**

All rental carpets ordered from AEX Convention Services are installed in clean condition.

**VACUUMING / SHAMPOO**

All rates are based on the total square footage of your exhibit space (100 sq. ft. minimum)

*Please check preference below:*

		Discount	Standard
<input type="radio"/>	One Time Vacuum carpet before initial opening of event	\$.37/sq. ft.	\$.52/sq. ft.
<input type="radio"/>	Daily Vacuum carpet before initial opening of event and daily thereafter over 1,000 Ft.	\$.31/sq. ft./day	\$.43/sq. ft./day
<input type="radio"/>	Shampoo Shampoo carpet once (specify day _____)	\$.26/sq. ft./day	\$.36/sq. ft./day
		\$.43/sq. ft./day	\$.60/sq. ft./day

Exhibit Space: \_\_\_\_\_ ft (x) \_\_\_\_\_ ft = \_\_\_\_\_ sq. ft. (x) \$ \_\_\_\_\_ (x) \_\_\_\_\_ = \$ \_\_\_\_\_  
(100 sq. ft. minimum) rate per sq. ft. Days Total

**PORTER SERVICE**

	Discount	Standard
Empty wastebasket, tidy and spot clean exhibit space at two hour intervals during show hours.	\$127.00	\$177.75

*Please check preference below:*

Daily  Once (Specify Day) \_\_\_\_\_ Date: \_\_\_\_\_

Porter Service: \_\_\_\_\_ days (x) amount per day \$ \_\_\_\_\_

SUBTOTAL ESTIMATED CLEANING ORDER: \$ \_\_\_\_\_

YES, I have completed and enclosed the Authorization and Agreement to Terms and Conditions Form and I understand that all orders are subject to Georgia State Sales tax 8%.

Company Name: \_\_\_\_\_ Booth#: \_\_\_\_\_



# GRAPHICS ORDER FORM

Please Mail or Fax Completed Form to: AEX Convention Services  
 3089 English Creek Ave., Egg Harbor Township, NJ 08234  
 Fax: (609) 272-1680 • Phone: (609) 272-1600

**Show Name: National Environmental Health Association**

**Show Dates: June 21-22, 2009**

**Deadline Date To Receive Discounted Rates: June 15, 2009**

**Our Experienced Team** is committed to providing accurate and professional trade show graphics using the most advanced equipment available.

## Trade Show Booth Panels • Banners • Backlits • Posters Signage • POP Displays • Table Drapes • Floor Graphics

### Full-Service Graphic Production

Looking for trade show graphics that will get you noticed? Why ship graphic materials to your show? We have full service graphic production capabilities that can meet your design and production needs and deliver the final product right to your booth! We'd be glad to take your graphic order and make it quick, make it easy and, of course, make it big!

**For more information call AEX Exhibitor Services at 609-272-1600.**

I AM SUPPLYING MY OWN ART ON DISK

I NEED ITEMS DESIGNED. SEE COPY AND LAYOUT SPECS BELOW.

### FULL COLOR DIGITAL POSTERS AND COUNTER CARDS

Description	Discount	Standard	Qty.	Total
7" x 11" Counter Card	\$33.50	\$47.00	_____	_____
7" x 44" Counter Card	\$41.00	\$57.50	_____	_____
11" x 14" Counter Card	\$43.50	\$61.00	_____	_____
9" x 44" Poster	\$37.75	\$52.75	_____	_____
14" x 22" Poster	\$52.50	\$73.50	_____	_____
14" x 44" Poster	\$69.00	\$104.00	_____	_____
22" x 28" Poster	\$72.50	\$108.75	_____	_____
26" x 95" Poster on Foamcore	\$158.50	\$222.00	_____	_____
28" x 44" Poster	\$121.75	\$170.50	_____	_____
Easel Back for Counter Card	\$7.25	\$10.25	_____	_____

### FULL COLOR DIGITAL BANNERS

Description	Discount	Standard	Qty.	Total
3' x 6'	\$210.00	\$294.00	_____	_____
3' x 8'	\$241.50	\$338.00	_____	_____
4' x 8'	\$278.25	\$389.50	_____	_____
Grommets	\$3.25	\$4.50	_____	_____
Pole Pockets	\$10.50	\$14.50	_____	_____

### COPY AND LAYOUT SPECIFICATIONS

**Indicate:** \_\_\_\_\_ Vertical or \_\_\_\_\_ Horizontal (Please attach a layout to this for if necessary)

**E-mail address for proofing is required:** \_\_\_\_\_

(Please note: Deadline for requesting a proof is 10 days prior to the first day of installation)

**SUBTOTAL GRAPHICS ORDER: \$** \_\_\_\_\_

**YES, I have completed and enclosed the Authorization and Agreement to Terms and Conditions Form and I understand that all orders are subject to Georgia State Sales tax 8%.**

**Company Name:** \_\_\_\_\_ **Booth#:** \_\_\_\_\_

AEX maintains a fully-equipped graphics shop that offers: Graphic Design, Large Format Printing, Backlit Graphics, Lamination, Vinyl Graphics, Vinyl Banners. For custom work and quotation, please call Exhibitor Services at 609-272-1600.



# FLORAL RENTAL ORDER FORM

Please Mail or Fax Completed Form to: AEX Convention Services  
 3089 English Creek Ave., Egg Harbor Township, NJ 08234  
 Fax: (609) 272-1680 • Phone: (609) 272-1600

**Show Name: National Environmental Health Association**

**Show Dates: June 21-22, 2009**

**Deadline Date To Receive Discounted Rates: June 15, 2009**

**SHOW SPECIAL \$150.00**

Two 5' Green Plants and fresh floral centerpiece of seasonal flowers  
 (Must be ordered by deadline date)

**Blooming Potted Plants - Indicate Color Selection**

Description	Discount	Standard	Qty.	Total
Azaleas - Available in season	\$40.00	\$56.00	_____	_____
Chrysanthemums - White/Yellow/Bronze/Purple	\$28.25	\$39.50	_____	_____
Other Flowering Plants - Please specify _____	\$40.25	\$56.25	_____	_____

**Tropical Green Plants - Circle Slim or Full**

Description	Discount	Standard	Qty.	Total
Ferns - Floor/Hanging (please choose)	\$41.00	\$57.50	_____	_____
3 Ft. - Slim or Full	\$51.00	\$71.50	_____	_____
4 Ft. - Slim or Full	\$62.25	\$87.25	_____	_____
5 Ft. - Slim or Full	\$84.75	\$118.50	_____	_____
6 Ft. - Slim or Full	\$93.50	\$131.00	_____	_____
7 Ft. - Slim or Full	\$101.25	\$141.75	_____	_____

**Flower Arrangements - Indicate Color, Style and Price**

Description	Discount	Standard	Qty.	Total
Arrange in Wicker Basket	\$56.50	\$79.00	_____	_____
Vase Arrangement	\$56.50	\$79.00	_____	_____
Centerpiece (Tall, low one side)	\$62.25	\$87.25	_____	_____
Exotic Arrangement (Birds of Paradise, Anthurim, etc.)	\$67.50	\$94.50	_____	_____

**Rose Arrangements - Indicate Color, Style and Price**

Description	Discount	Standard	Qty.	Total
Color: _____	\$84.75	\$118.50	_____	_____

**Balloons**

Description	Discount	Standard	Qty.	Total
Mylar Balloons - Indicate Style _____	\$6.00	\$8.50	_____	_____
Latex Balloons - Indicate Color _____	\$3.50	\$5.00	_____	_____

**To ensure your floral request, please order no later than 4 days prior to show opening. Orders after that time will be on available basis only.**

Due to the seasonal nature of flowers, please indicate your phone number and contact person so that we may confirm your order and let you know what is in season.

Note: Exhibitors are responsible, up to one hour after the published closing time of the show, for safeguarding all rented plants, containers and materials until picked up by a floral representative. Missing material shall be billed to the exhibitor at twice the standard rental fee.

**Phone:** (\_\_\_\_) \_\_\_\_\_ **Contact:** \_\_\_\_\_

**SUBTOTAL FLORAL RENTAL ORDER: \$** \_\_\_\_\_

**YES, I have completed and enclosed the Authorization and Agreement to Terms and Conditions Form and I understand that all orders are subject to Georgia State Sales tax 8%.**

**Company Name:** \_\_\_\_\_ **Booth#:** \_\_\_\_\_



## UNION JURISDICTIONS AND RULES

Please Mail or Fax Completed Form to: AEX Convention Services  
3089 English Creek Ave., Egg Harbor Township, NJ 08234  
Fax: (609) 272-1680 • Phone: (609) 272-1600

**Show Name: National Environmental Health Association**

**Show Dates: June 21-22, 2009**

### **Hyatt Regency - Atlanta**

Trade shows and events held in Atlanta hotels are subject to union jurisdictions that affect exhibitors. You will find the jurisdictions are comparable, and in many cases more user friendly, to other union facilities. This outline is designed to assist you by answering the most frequently asked questions.

#### **Freight & Material Handling**

You may ship goods, via the carrier of your choice, to either AEX Convention Services' advance warehouse or direct to show site for arrival during the published receiving periods. Material Handling (drayage) is within the Decorator's union jurisdiction (unload, deliver, remove, and reload freight). Material Handling may be ordered using the "Material Handling Order Form" provided in the kit and is entirely distinct from shipping. Exhibitors may, at their option, handle their own freight using their own moving equipment at show site.

#### **Furniture & Carpet**

Furniture and carpet may be rented using the "Furniture Rental Order Form" and the "Carpet Rental Order Form" which are provided in the kit. The price includes union labor for delivery, installation, and removal.

#### **Booth Erection & Dismantling**

The Decorators union has jurisdiction over the erection and dismantling of displays and exhibits and may be hired to install exhibitor owned carpet, padding, flooring, hang signs, etc. Labor can be ordered using the "Labor Order Form" in the kit. Exhibitors may, at their option, erect and dismantle their own booths. Rigging crews may to be hired to move large machinery within booths and can be ordered using the "Forklift & Rigging Crew Order Form" provided in the kit. Exhibitors may supply their own flooring (carpet, carpet padding, tile, wood, etc.). However, all flooring must be installed and removed by AEX Convention Services' labor, using the "Labor Order Form" enclosed in the kit.

#### **Electric**

The hotel electrical staff handles electrical needs, connections and installing powered signs and headers. Their services may be ordered directly from the facility using the form provided in the kit.

#### **Tipping**

AEX Convention Services requests that exhibitors do not tip our employees. They are paid an excellent wage scale denoting a professional status, and we feel that tipping is not necessary. This applies to all AEX Convention Services' employees and its subcontractors.

#### **Safety**

Standing on chairs, tables or other rental furniture is prohibited. The furniture is not engineered to support your standing weight. AEX Convention Services is not responsible for injuries caused by improper use of this furniture.

Please assist in our efforts to provide a safe working environment for everyone. If you would like additional information or how the jurisdictions may apply to you and your exhibit, please call AEX Convention Services at (609) 272-1600 for assistance.

# LibertyCFS Inc.

Tel: 905-338-3993 ♦ Fax: 905-338-1092

## The Liberty Advantage

Heading off to a tradeshow? Whether you are a seasoned professional or a first timer, LibertyCFS Inc. is there to help you with any of your logistical needs. Let our team of transportation experts guide and support you through the entire process. LibertyCFS Inc. offers complete worldwide air and sea freight forwarding services that are 100 % devoted to tradeshow and conventions. We design solutions, tailored to fit your shipping needs, be it across town, or across the continent

## Transportation

At Liberty, we focus everyday on making your tradeshow experience a success, and we build competitively priced transportation solutions to do it.

- *Overnight*
- *2nd Day Service*
- *Economy Air*
- *International Freight Forwarding*

## Exhibitor Services

### *Pre-Show Support*

- Liberty will help you choose the most effective shipping solution, tailored to your needs and budget
- Tracking your freight and monitoring its progress, from your office to the show-site
- On-call freight professionals, every day, all day, answering your questions and giving you peace of mind

### *Show-time Support*

- Liberty people are on-site supervising the loading and un-loading of your freight, making sure it is on-site, on time.
- On-site freight experts throughout the event, keeping you informed and prepared for the journey home

### *Post-Show Support*

- Tracking your freight to its destination and making sure it arrives safely, on time and without incident
- Follow-up contact after the event to ensure your satisfaction with our services

***Complete the Order Form on the reverse side of this page or download it at [www.libertycfs.com](http://www.libertycfs.com) to order your freight services now. You may also speak to your LibertyCFS Exhibitor Services Representative at 905-338-3993***

***“Delivering Freedom”***



Transportation Services

# Order Form

# LibertyCFS Inc

Tel: (905)338-3993 Fax: (905) 338-1092

Please accept this form as your authority to provide Customs and/or Transportation services.

We wish to use Liberty CFS Inc. for the following: (Pick One)

Customs & Transportation       Customs Only       Transportation Only

Shipper	Company			Consignee	Exhibitor		Booth
	IRS #				Event		
	Address				Address		
	Address				Address		
	City	State	Zip		Address		
	Contact				City	State	Zip
	Phone	Fax			Contact		Phone
Bill to	Company			Return Freight to	Company		
	Address				Address		
	Address				Address		
	City	State	Zip		City	State	Zip
	Contact				Contact		Phone
	Phone	Fax			Arrive by Date		
Credit Card	Charge to:	<input type="checkbox"/> Visa <input type="checkbox"/> Master Card <input type="checkbox"/> AMEX					
	Card Number				Expiry Date		
	I hereby authorize the use of this card for payment of services related to this order form. I understand that declined credit cards are subject to a 30% surcharge.			Card Holder Name			
				Signature			
<h2>Transportation Info</h2>				Service Requested:			
Pick up Date		Time		<input type="checkbox"/> Express 2 Day <input type="checkbox"/> Economy 3-5 Day			
Delivery Date		Time		<input type="checkbox"/> Other (Specify below)			
				Service required <input type="text"/>			
Description of Packages/Contents				Declared Value for Carriage			
Cartons / Boxes	<input type="text"/>	Dimensions		The declared value for carriage of this shipment is agreed to and understood to be \$0.50 per pound multiplied by the number of pounds of that part of the shipment lost or damaged but not less than \$50.00 per shipment unless a value is declared below and applicable charges paid thereon. Subject to the Terms and Conditions on reverse side the liability of Forwarder for loss/damage is as stated below.			
Vinyl Cases	<input type="text"/>	<input type="text"/>					
Wooden Crates	<input type="text"/>						
Flat Pieces	<input type="text"/>	Description of Goods					
Skids / Palettes	<input type="text"/>	<input type="text"/>		Enter Amount \$ <input type="text"/>			
Trunks	<input type="text"/>	<input type="text"/>		<b>FAA/DOT Security Approval: Known/Unknown Shipper Security and Hazardous Material Declaration</b> I certify that this shipment does not contain any unauthorized explosives, destructive devices or hazardous materials. I consent to search of this shipment. I am aware that this endorsement and original signature, along with other shipping documents, will remain on file until this shipment is delivered. I also certify that the described materials are properly classified, described, packaged, marked and labeled and are in proper condition for transportation according to the applicable regulations of DOT			
Tubes	<input type="text"/>	<input type="text"/>					
Other	<input type="text"/>	<input type="text"/>					
Total	<input type="text"/>	Weight		Signature _____			
		<input type="checkbox"/> LBS <input type="checkbox"/> KGS					

Transportation & Customs Services

Print Form

Fax to: 905-338-1092

Reset Form



# Hyatt Regency Atlanta - Engineering Department

265 Peachtree Street, NE, Atlanta, Georgia 30303-1294

Phone: 404-460-6360 Fax: 404-460-6375

Email: [electric@hyatt.com](mailto:electric@hyatt.com)

Print Form

## ELECTRICAL AND SPECIAL SERVICES REQUEST AND RENTAL FORM

Show Name \_\_\_\_\_ Set-Up Date \_\_\_\_\_ Booth # \_\_\_\_\_  
 Company Name \_\_\_\_\_ Ordered By \_\_\_\_\_ Phone # \_\_\_\_\_  
 Onsite Contact \_\_\_\_\_ Phone # \_\_\_\_\_ (Mobile Preferred)

### CONVERSION CHART AND RATES FOR STANDARD ELECTRICAL SERVICES (A)

AMPS	1 PHASE 120 VOLTS	1 PHASE 208 VOLTS	3 PHASE 208 VOLTS	AMPS	1 PHASE 208 VOLTS	3 PHASE 208 VOLTS
20	2,000 watts \$185	3,300 watts \$250	5,800 watts \$425	60	10,000 watts \$625	17,300 watts \$1,000
30	---	5,000 watts \$325	8,600 watts \$575	100	16,600 watts \$975	28,800 watts \$1,650
40	---	6,600 watts \$400	11,500 watts \$725	200	---	57,600 watts \$3,200
50	---	8,300 watts \$500	14,400 watts \$825	400	---	143,900 watts \$5,625

### ADDITIONAL SERVICES AND LABOR CHARGES (B)

<b>Water:</b> Hot Water - \$210, Cold Water - \$210, Drain - \$140, Fill & Drain (Up to 400 Gal) - \$245 Hook up to Equipment Available - \$70 (Note: Booth location must be specifically arranged with Exhibit Contractor)	<b>Equipment Rental:</b> Extension Cord Rental - \$50 (25ft) & \$100 (50ft), Power Strip Rental - \$50 Clamp-On Light, 150 watt, includes power and hook-up - \$165
<b>Air:</b> Up to 80cfm, terminated in 1/2" FPT fitting at back of booth; no hook-up - \$450, (Plz advise of PSI, CFM, Intermittent or Continuous) Hook-Up to Equipment Available - \$70 (Note: Booth location must be specifically arranged with Exhibit Contractor)	<b>Electrical Labor Charges Section</b> (See Information On Back Of Form): Straight Time, 8a - 4p, M - Sa: \$67.50 Overtime, 4pm - 8a, M - Sa: \$101.25 Doubletime, Sun. & Holiday: \$135.00

### ELECTRICAL SERVICES (A)

QTY.	AMPS	VOLTS	PHASE	UNIT PRICE	\$ AMOUNT
Subtotal A					

### ADDITIONAL SERVICES AND LABOR (B)

QTY.	ITEM DESCRIPTION	UNIT PRICE	\$ AMOUNT
Subtotal B			
Total A+B			
Grand Total			

Order form with payment received seven (7) days prior to SET-UP date - CHECK BOX TO DEDUCT 10%   
 (Standard pricing will apply for all orders received within seven (7) days of the set-up date)

### PAYMENT INFORMATION

**Total Order \$** \_\_\_\_\_

Payment in Full must be received prior to installation of services. Please indicate your method of payment:

\_\_\_\_ CHECK ENCLOSED IN THE AMOUNT OF \$ \_\_\_\_\_ (Payable to Hyatt Regency Atlanta)  
 \_\_\_\_ CHARGE MY CARD IN THE AMOUNT OF \$ \_\_\_\_\_

( ) Am Ex ( ) M/C ( ) Visa ( ) Other \_\_\_\_\_

**CREDIT CARD AUTHORIZATION:** Your signature authorizes Hyatt Regency Atlanta to DEBIT your credit card for all charges associated with this order. Hyatt Regency Atlanta reserves the right to disconnect power if a credit card is declined or invalid. For your convenience, we will use your credit card authorization to charge any additional amounts incurred as a result of showsite orders placed by you or your organization.

Credit Card Number _____	Expiration Date _____	Print Name As It Appears on Credit Card _____
Authorizing Signature _____		Date Authorized _____

**THESE PRICES ARE GOOD UNTIL DECEMBER 31, 2009. THE HOTEL MUST BE CONTACTED FOR A CURRENT FORM BEGINNING JANUARY 1, 2010.**

## LABOR

Labor Rates are subject to labor contracts in effect at the time of Show. Labor before 8:00am and 4:00pm, Monday - Saturday will be at the overtime rate. Labor on Sunday & Holidays will be at the double-time rate.

OK to proceed without exhibitor supervision, per attached Floor Plan.

Date(s) Requested \_\_\_\_\_

Time Requested \_\_\_\_\_

No. of Electricians \_\_\_\_\_

### Specify Labor Required:

\_\_\_\_\_ Electrical Distribution                      \_\_\_\_\_ Electrical Motor or Controls

\_\_\_\_\_ Electrical Distribution Overhead                      \_\_\_\_\_ Electrical Fixtures

Starting time can be guaranteed only in those instances when Electrical Labor is requested for the start of the working day, which is 8:00am, if not previously committed. A minimum charge per booth of one hour for installation and one-half hour to dismantle will apply, and time will commence in accordance with exhibitor's request.

Failure to start labor at requested time will result in a one hour charge, per electrician requested, unless 24 hour advance notice is provided.

## ELECTRICAL REGULATIONS & GENERAL INFORMATION

1. Hyatt Regency Atlanta is not responsible for voltage fluctuation or power failure due to temporary conditions. For your protection you should install a surge protector on your computer(s). All electrical installations and connections to all electrical service should be made by a Hyatt Regency Atlanta electrician. Hyatt Regency Atlanta will not be responsible for any damage or lost equipment, component computer hardware or software and/or any damage or injury to any person caused by the installation, connection or plugging into any electrical outlet by person other than a Hyatt Regency Atlanta electrician.
2. Electricity will be turned on within 30 minutes of show opening and turned off within 30 minutes after show closing.
3. Twenty-four hour service to any outlet will be double the listed price.
4. Dedicated power is double the listed price, and can only be guaranteed before show opening with advance arrangements for date needed.
5. All electrical outlets will be installed on the floor at the draped back wall of in-line booths and peninsula spaces. Exhibitors with hard wall displays must arrange for power to be dropped inside the booth if necessary; this will be done on a time and material basis. Overhead power to island booths will be dropped to one main location per the exhibitor's floorplan. If no plan is provided, the power will be installed at our discretion. Additional power drops are chargeable on a time and material basis. Distribution and connection(s) to equipment is chargeable on a time and material basis.
6. Local ordinances allow only 2000 watts per lighting circuit and only one connection for power and motor outlets.
7. All wiring, motors, electrical installations, etc. must be approved. To prevent overloading of circuits, exhibitors cannot add wattage except as ordered.
8. All electrical permits required by the Local Building and Safety Code will be obtained by the electrical contractor.
9. All flood light, column, and wall outlets are not a part of booth space. A separate outlet must be ordered at regular price for each piece of equipment to be connected.
10. Special hanging, hookups, repairs or installation of electrical will be done on a time and material basis.
11. All equipment should be property tagged and wired with full information as to current, voltage, Phase, cycle, horsepower, etc. and ready for connection. If special or specific receptacles are required for equipment, they should be supplied by the exhibitor and installation will be charged at labor rates.
12. All outlets 20 amps and over with a voltage of 150 volts and over require electrical labor. This includes a 1 hour minimum to inspect exhibitors that are pre-wired to plug into our system.
13. No credits will be issued on outlets or lights installed as ordered even though not used.

## ELECTRICAL CONTRACTOR'S RESPONSIBILITIES

As the Official Electrical Contractor, we will be responsible for:

- All under-carpet distribution of electrical wiring.
- All facility overhead distribution of electrical wiring, including coaxial cable, fiber optics and the distribution of same from product to booth and from booth to booth.
- All motor and equipment hookups requiring hard wire connections.
- Installation and/or repair of electrical fixtures.
- Installation of electrical motors to be energized and electrical apparatus.

The above items require electrical labor, which may be ordered in the Electrical Labor section on the reverse side.

## ELECTRICAL CODE

Electrical requirements for an exhibit at all convention facilities are for the safety of all exhibitors and are based on national Electrical Codes and local ordinances.

Fires can result from faulty wiring, carelessness or lack of understanding of the risks involved.

In the interest of public safety, exhibits in the convention facilities may be inspected to determine if any violations exist. If they are found, qualified electricians are available to correct the problems. This work will be performed on a time and material basis. If the exhibitor does not wish to have the fault corrected, electrical service to the offending booth will be disconnected.

If an exhibitor is not knowledgeable or does not understand basic safety standards for electrical wiring, an electrician should be consulted before shipment is made to convention facilities.

Serious risks are involved which can be eliminated by understanding basic requirements of safe wiring inside your booth. For the safety of you and the public, remember these points:

- All wiring must have a 3-wire grounded cord with minimum of ~14 gauge.
- Spot or flood lighting is a hazard when lamps are too close to fabrics or other material that can be affected by heat.
- The use of clip-on sign sockets, latex or lamp cord wire in displays, or the use of 2-wire clamp-on fixtures, is prohibited by order of fire prevention bureaus at trade shows and conventions.
- Zip cords or two-wire cords are ungrounded and could result in safety hazards. Their use is strictly prohibited in all convention facilities.
- Inspect all internal wiring and connections frequently.

The use of 2-wire cords are prohibited

**SWISSCOM HOSPITALITY SERVICES EXHIBITOR ORDERING INSTRUCTIONS**  
**\*PLEASE READ THOROUGHLY TO ENSURE A COMPLETE SERVICE REQUEST\***

1. **Fill out the accompanying forms completely:** include contact (ordering and onsite), payment information and signatures on all faxed or mailed service requests.
2. **Using a credit card for payment:** completely fill out the payment/credit card authorization form. Make sure signature is the same as the credit card holder's name; also attach a copy of the credit card holder's driver's license with the form. *\*Charges will appear as Hyatt Regency Atlanta\**
3. **Using a check for payment:** Mail original check with service order form to Hyatt Regency Atlanta 265 Peachtree Street, N.E. Atlanta, GA 30303. Make out to Hyatt Regency Atlanta - ATTN: Swisscom Hospitality Services.  
*\*\*\*DO NOT MAKE CHECKS OUT TO SWISSCOM HOSPITALITY SERVICES DIRECTLY\*\*\**
4. **Include service drop location within your booth:** On the bottom of the order form is a diagram for service location. Simply fill in the blank lines with orientation (i.e. front, back and/or adjacent booth numbers) and mark an (X) within the diagram for drop location. *\*\*\*Charges may apply for service relocations\*\*\**
5. **Additional network devices (more than one):** When ordering services you will receive one routable IP address as well, any additional devices using network resources (regardless of IP addressing scheme) will be subject to an additional device fee, charged per device. Simply order additional device/IP addresses for these connections (in excess of the one included IP address), all hubs and cabling will be provided.  
*\*\*\* You will not be permitted to use access points, switches or hubs without paying for the additional devices\*\*\**
6. **Terms & Conditions:** Please read through the accompanying terms and conditions as you are acknowledging such with your order form signature.
7. **Services not covered by this form:** More network solutions such as; VLAN(s), videoconferencing, WiFi Hotspots, Webcasting and more are available upon request. Email requests for a customized solution to W. Richard Newton/rnewton@core.net.
8. **Fax or mailing your order:**  
1-775-248-6651 or Hyatt Regency Atlanta/265 Peachtree Street, NE Atlanta, GA 30303  
C/O Swisscom Hospitality Services
  - a. **A completely filled out exhibitor form:** including ordering/onsite contact info, set-up time and service location diagram.
  - b. **A completely filled out payment form:** Check/CC info with signature and a copy of the driver's license. If you are not comfortable sending this to our private and secure fax, please call and we will accommodate you as we protect information vigorously.
  - c. **Make sure both the order and payment form are signed:** this will make sure there are no delays in your service request(s).
9. We will contact you within 48 hours of fax receipt via e-mail or telephone and supply you a service invoice for your records.
10. Questions? Contact Swisscom Hospitality Services – Number, (Time Zone) or Email  
W. Richard Newton 678-234-8007 1-775-248-6651 rich.newton@swisscom.com



## Hyatt Regency Atlanta ♦ Telephone Service Order Form

Phone: 404-577-1234

Fax: 404-588-4137

Conference Name: _____	
Company Name: _____	Contact Name: _____
Address: _____	
Phone #: _____	Master #: _____
Credit Card #: _____	Expiration: _____

	Cost	# of Lines	# of Phones	Install Date	Remove Date & Time	Location/Booth/Room
<b>Communication Services</b>						
<b>DID Long Distance Lines Installation Charge</b>	\$225					
~Dial 9 + phone number	\$50					
Each additional day + Calls						
<b>House Phone Installation Charge</b>	\$150					
~Dial 9 + phone number	\$50					
Each additional day + Calls						
<b>Dedicated BellSouth Line (See Notes)</b>	\$300					
~Phones calls billed 30 days later	\$50					
Each additional day						
<b>ISDN Line / Plus Calls</b>	\$700					
<b>In-House Video Channel Rental (Per Day Rate)</b>	\$1,000					
<b>Equipment Rental Cost</b>						
~Polycom Conference Phone (one-time)	\$400					
~Standard Speaker Phone (per day)	\$125					
~Phone Rental (per day)	\$15					
~Multi-Line Phone Rental (per day)	\$100					
~Hunt Group (one-time charge)	\$75					
~Voice Mail (one-time charge)	\$75					
~T1 Rental	For T1 lines and Internet Service prices, please call SwissComm at 404-460-6346.					

**NOTES:**

- All requests for service should be faxed directly to the Communications Department at 404-588-4137.
- For BellSouth lines, BellSouth requires three weeks advanced notice.
- For all other services, seven days advanced notice is required. If you are unable to provide us with seven days advanced notice, there will be an additional service charge of \$50 for onsite orders.
- There will be a \$100 charge for each phone not returned to the Communications Department.

## HYATT REGENCY ATLANTA

Hyatt Regency Atlanta's display rules and regulations are based on a philosophy that all Exhibitors should be given an equal opportunity to present their product to their audience in an effective manner.

The Following apply to all Exhibits.

**Adhesives** - No pins, tacks or adhesives of any kind are permitted on any wall, door or column. Adhesive backed stickers may not be given out by exhibitors.

**Signs/Banners** - All hanging signs must be professionally made and conform to show management rules, regulations and ceiling limitations. All pre-assembly of hanging signs and truss must be done by GES. All hanging signs and truss must be hung by GES. No other firm will be allowed to access to the Hotel's ceiling. GES and the Hotel reserve the right to refuse to hang any sign and truss it deems unsafe or inappropriate.

**Non-Flammable Materials** - All materials used in the Grand Hall or any other part of the Hotel must be non-flammable in order to conform with the fire regulations of the City of Atlanta.

**Compressed Gases** - Compressed gases are not allowed inside the Hotel. Heavier than air gases like propane, butane or liquefied petroleum gas (LPG) are also not allowed.

**Motorized Vehicles** - All motorized vehicles are to have comprehensive general liability insurance in a minimum amount of \$2,000,000 in addition to a signed waiver for indemnification/hold harmless. Both of these documents must be supplied to the hotel prior to arrival/set up date. All cars, trucks or other types of fuel powered engines on display must have the least amount of fuel possible (between 1/8 of a tank and empty). The gas cap must be a locking type or taped to prevent the leakage of fumes from the tank. Battery cables must be disconnected. Vehicles may not be started, run or moved during event hours. Transfer of fuel must be accomplished outside the building.

**Liability** - The Hotel is not responsible for any injury, loss or damage that may occur to the Exhibitor, the Exhibitor's Agent, employees or property, or to any other person's property, prior, during or subsequent to the period covered by the exhibit contract, provided said injury, loss or damage not caused by the willful negligence of an employee of the Hotel. Each Exhibitor hereby expressly releases the Hotel from such liabilities and agrees to indemnify the Hotel against all claims for such injury, loss or damage.

**Insurance** - Exhibitors who desire to carry insurance on their own exhibits must do so at their own expense.

**Shipping** - The Hotel has the right to refuse any delivery addressed to Hotel for an exhibition show. In addition the Hotel has the right to consign any deliveries to GES and charge an additional handling fee.

**Storage** - The Hotel has no facilities for the storage of exhibits. All shipments must be directed to GES.

**Food and Beverage** - Any food or beverage dispensed or given away at a booth must be supplied and prepared by the Hotel staff.

**Balloons** - Helium filled balloons are not permitted in the Grand Hall.

**Tape** - Exhibitors are responsible for the removal of all tape and residue marks.

**Smoking** - Due to the Fulton County "Clean Air Ordinance", smoking is not allowed in the Grand Hall or in any public area of the Hotel.

**Right to Inspect** - The Hotel's Security personnel reserves the right to inspect any carton, container, briefcase, luggage or package brought in to or taken out of the Grand Hall.

**Exhibitor Equipment** - All equipment, decorations, freight, etc. must be removed from the premises at the expiration of the Show. Items left behind will be treated as abandoned equipment.

**Access for Deliveries** - All articles, exhibits, fixtures, displays and property of any kind shall be brought in to and out of the Grand Hall only at and through such approved loading area as the Hotel may designate.

X \_\_\_\_\_



**SHOW NAME:**

**HYATT REGENCY ATLANTA  
ATLANTA, GA**



Video Equipment	Qty	DAILY RATE		Days Used	Total	Customer Information	
		Advanced	On Site				
1/2" VHS Player with "end of tape" Repeat		\$110.00	\$132.00			Name:	
DVD Player		\$75.00	\$90.00			Address:	
Sony Betacam SP player		\$550.00	\$660.00			City:	
32" Color Monitor Only ( for vhs or dvd only)		\$160.00	\$192.00			State:	Zip:
54" Rolling Cart w/Black Skirt		\$30.00	\$36.00			Telephone #:	
4', 5' or 6' Tripod Screen		\$60.00	\$65.00			Booth #	
TV Cable Connection (per line)		\$50.00	\$75.00			Fax #:	
**TV Cable Connection price is based on location						Email Address:	
and total number needed-please see Audio Visual Dept.							
Other:							

Audio Equipment	Qty	DAILY RATE		Days Used	Total	Ordering Instructions	
		Advanced	On Site				
CD Player*		\$60.00	\$72.00			<p><b>The total charge per item is determined by multiplying the quantity by the daily rate by the number of days to be used.</b></p> <p>rental. <b>TAX EXEMPT STATUS</b> - If you are exempt from payment of sales tax, we require you to forward an exemption certificate for the state in which the services are to be provided.</p> <p>⇒ To guarantee equipment availability and advanced rate, Complete this form in it's entirety atleast seven (7) days before the event start day.</p> <p>⇒ Operator labor, if requested, is subject to the prevailing day rates @ 10 hours.</p> <p>⇒ <b>CANCELLATIONS:</b></p> <p>A) Cancellation of equipment ordered must be received <b>48 hours prior</b> to delivery date to avoid a minimum one day charge.</p> <p>B) If services have already been provided at the time of cancellation, 50% of original charges will be applied.</p>	
Wired Microphone: Handheld *		\$60.00	\$72.00				
Wired Microphone: Lavalier *		\$75.00	\$90.00				
Wireless Microphone: Handheld / Lavalier / Headset*		\$185.00	\$222.00				
4 Channel Mixer*		\$70.00	\$84.00				
Powered Speaker with stand*		\$80.00	\$96.00				
Laptop Audio *		\$50.00	\$75.00				
*****additional equipment may be required for all audio equipment please contact AV Department directly*****							
Other:							

Computer /Display Equipment	Qty	DAILY RATE		Days Used	Total
		Advanced	On Site		
20" Flat screen monitor		\$175.00	\$210.00		
37" Flat screen monitor		\$300.00	\$360.00		
50" Plasma Display w/stand		\$400.00	\$480.00		
Laptop		\$250.00	\$300.00		
Desktop Computers (pricing is based on availability and specifications)					
Other:					

Packages	Qty	DAILY RATE		Days Used	Total
		Advanced	On Site		
TV/DVD/VCR Combo Package(includes TV, DVD/VCR combo unit and cart		\$350.00	\$420.00		
LCD Package (includes screen, projector, projection cart and cabling)		\$455.00	\$475.00		
LCD Support Package( includes screen, projection cart and cabling)		\$185.00	\$222.00		
Flipchart Package (includes one pad, four markers, and stand)		\$55.00	\$80.00		

Rental Totals		PAYMENT IS DUE WHEN ORDER IS PLACED	
EQUIPMENT TOTAL	1		
LOSS DAMAGE WAIVER (7.% of line 1)	2		
DELIVERY/SETUP/PICKUP (22% of line 1, or \$50 minimum whichever greater)	3		
SUBTOTAL	4		
SALES TAX (8% of line 1)	5		
TOTAL DUE	6		

Delivery Information	
On-Site Contact:	
Exhibit Area (circle one): Grand Hall Hanover ACC Embassy Ballroom	
Booth #:	Room:
Delivery Date:	Time:
Pickup Date:	Time:
Cell Number	
Conference/Meeting Name:	

Method of Payment	PLEASE CHECK ONE	
Card Number: _____ Exp Date ___ / ___	American Express	<input type="checkbox"/>
	Visa	<input type="checkbox"/>
Cardholder's Name (as appears on card): _____	MasterCard	<input type="checkbox"/>
Cardholders Signature: _____		
(Check must be received seven days before the event start date)	Check	<input type="checkbox"/>

Return for Processing
<p><b>Swank Audio Visuals</b></p> <p><a href="mailto:303ha@swankav.com">303ha@swankav.com</a></p> <p><b>HYATT REGENCY ATLANTA</b></p> <p><b>265 Peachtree Street NE</b></p> <p><b>Atlanta, GA, 30303</b></p> <p><b>PHONE: 404-460-6550</b></p> <p><b>FAX: 404-460-6564</b></p>